

Split Core Hall Effect DC Current Sensor CYHCT-C2TV

This Hall Effect current sensor is based on open loop principle and designed with a split core and a high galvanic isolation between primary conductor and secondary circuit. It can be used for measurement of DC current etc. The output of the transducer reflects the real wave of the current carrying conductor.

Product Characteristics	Applications
<ul style="list-style-type: none"> • Excellent accuracy • Very good linearity • Light in weight • Less power consumption • Window structure • Electrically isolating the output of the transducer from the current carrying conductor • No insertion loss • Current overload capability 	<ul style="list-style-type: none"> • Photovoltaic equipment • Frequency conversion timing equipment • Various power supply • Uninterruptible power supplies (UPS) • Electric welding machines • Numerical controlled machine tools • Electrolyzing and electroplating equipment • Electric powered locomotive • Microcomputer monitoring • Electric power network monitoring

Electrical Data/Input

Primary Nominal DC Current I_r (A)	Primary Current Measuring Range I_p (A)	DC Output Voltage (V)	Part number
25A	0 ~ ±25A	x=0: 0-4V ±1.0% x=3: 0-5V ±1.0% x=8: 0-10V ±1.0%	CYHCT-C2TV-U/B25A-xnC
30A	0 ~ ±30A		CYHCT-C2TV-U/B30A-xnC
40A	0 ~ ±40A		CYHCT-C2TV-U/B40A-xnC
50A	0 ~ ±50A		CYHCT-C2TV-U/B50A-xnC
100A	0 ~ ±100A		CYHCT-C2TV-U/B100A-xnC
200A	0 ~ ±200A		CYHCT-C2TV-U/B200A-xnC
300A	0 ~ ±300A		CYHCT-C2TV-U/B300A-xnC
400A	0 ~ ±400A		CYHCT-C2TV-U/B400A-xnC
500A	0 ~ ±500A		CYHCT-C2TV-U/B500A-xnC
600A	0 ~ ±600A		CYHCT-C2TV-U/B600A-xnC

(n=2, V_{cc} = +12VDC; n=3, V_{cc} =+15VDC; n=4, V_{cc} =+24VDC, U: unidirectional, B: bidirectional)
(Connector: Molex connector C=M; Phoenix Connector: C=P, Cable connection: C=S)

Supply Voltage:	V_{cc} =+12V, +15V, +24V± 5%
Current Consumption	I_c < 25mA
Isolation Voltage	2.5kV, 50/60Hz, 1min
Output Voltage at I_r , T_A =25°C:	V_{out} =0- 4V, 0-5V, 0-10VDC
Output Impedance:	R_{out} < 150Ω
Load Resistor:	R_L > 10kΩ

Accuracy

Accuracy at I_r , T_A =25°C,	X <1.0% FS
Linearity from 0 to I_r , T_A =25°C,	E_L <1.0% FS
Electric Offset Voltage, T_A =25°C,	V_{oe} <50mV
Magnetic Offset Voltage (I_r →0)	V_{om} <±20mV
Thermal Drift of Offset Voltage,	V_{ot} <±1.0mV/°C
Thermal Drift (-10°C to 50°C),	T.C. < ±0.1% /°C
Response Time at 90% of I_p (f =1k Hz)	t_r < 1ms
Frequency Bandwidth (-3dB),	f_b = DC - 20 kHz

Case Material:
Ambient Operating Temperature,
Ambient Storage Temperature,

PBT
 $T_A = -25^\circ\text{C} \sim +85^\circ\text{C}$
 $T_S = -40^\circ\text{C} \sim +100^\circ\text{C}$

PIN Definition and Dimensions

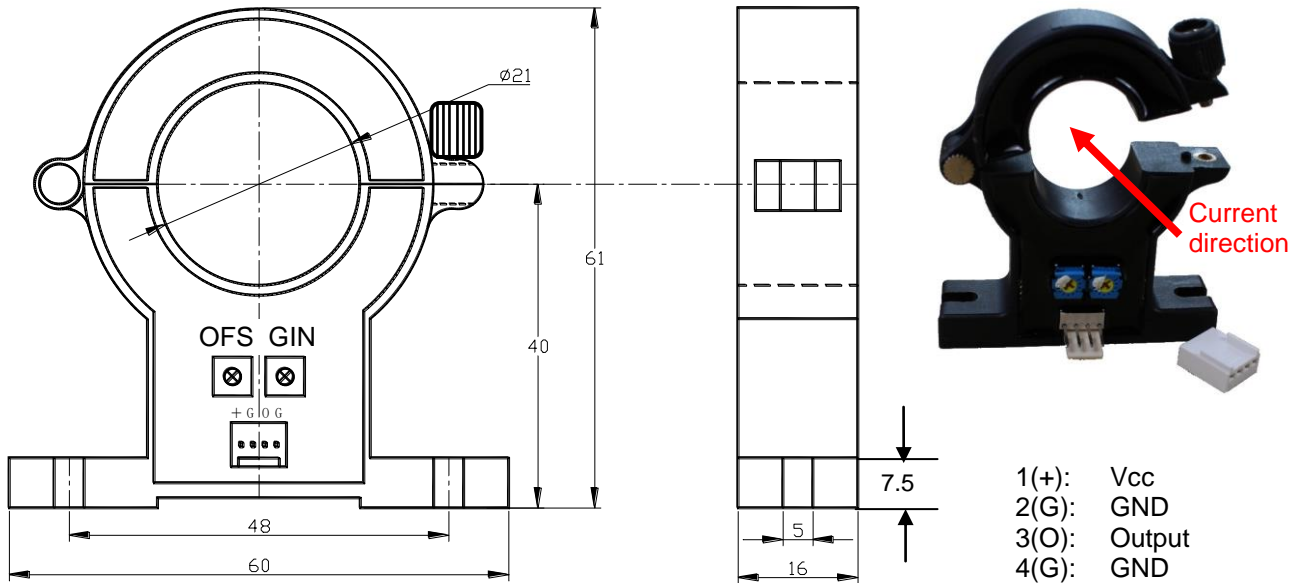

OFS: Offset Adjustment

GIN: Gain Adjustment

Connection

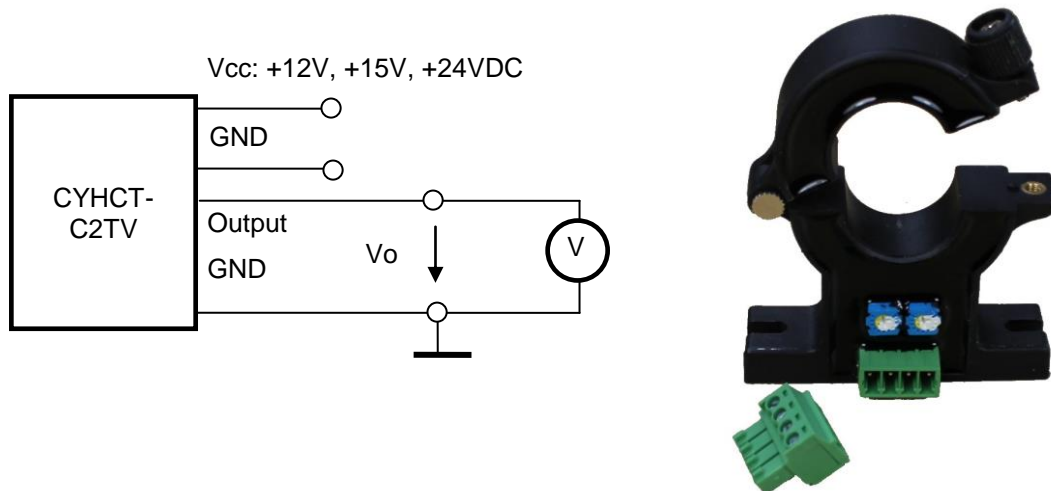

Cable Connection

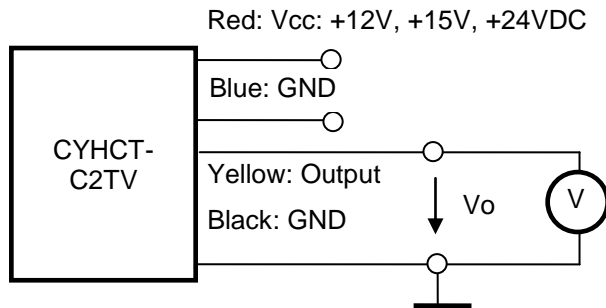

Wire Arrangement:

Red: Vcc: +12V, +15V, +24VDC
Blue: GND (ground)
Yellow: Vo (Voltage output)
Black: GND (ground)



Notes:

1. Connect the terminals of power source, output respectively and correctly, never make wrong connection.
2. Two potentiometers can be adjusted, only if necessary, by turning slowly to the required accuracy with a small screwdriver.
3. The best accuracy can be achieved when the window is fully filled with bus-bar (current carrying conductor).
4. The in-phase output can be obtained when the direction of current of current carrying conductor is the same as the direction of arrow marked on the transducer

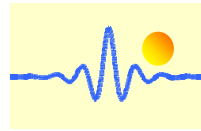

DIN Rail Adapter CY-DRA88

The DIN Rail Adapter CY-DRA88 is designed for mounting the sensor on 35mm DIN Rail. It has the size 70 x 24 x 23mm. The height from bottom to mounting surface is 14.8mm.

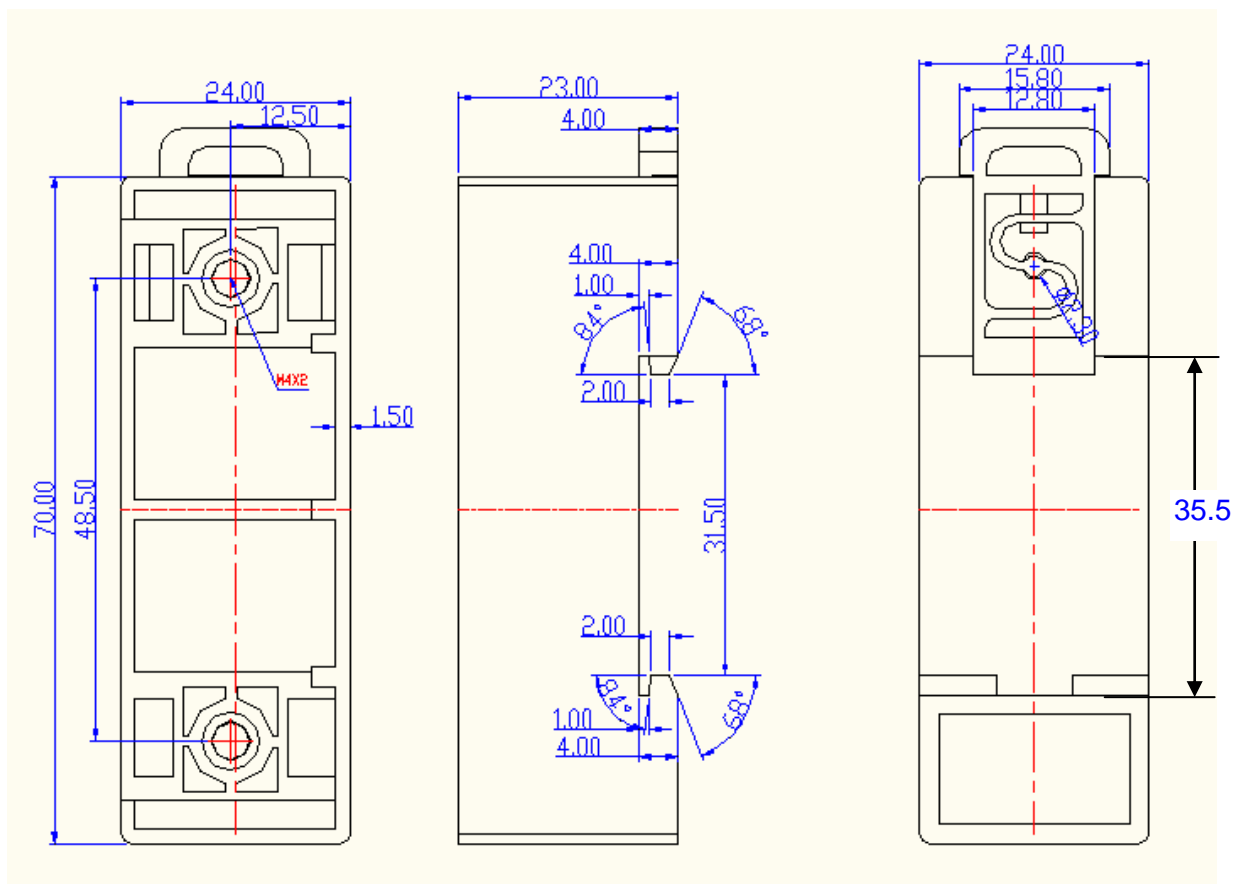
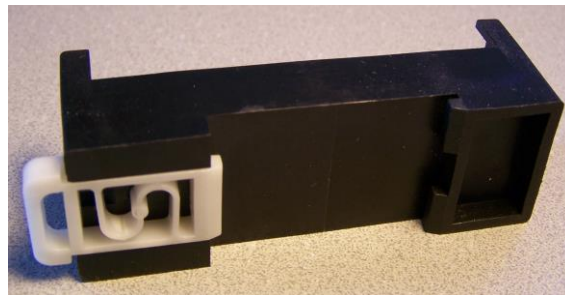

Mounting of Sensors



Sensor with Molex Connector
(The distance between the bottom und the middle of hole is 54.8mm)



Sensor with Phoenix Connector
(The distance between the bottom und the middle of hole is 54.8mm)