

Linear Hall Effect Sensor CYSJ15A

CYSJ15A Hall Effect Sensor is outstanding for its Ultra-High sensitivity and its low temperature coefficients. This sensor is made by using the technique of Molecular Beam Epitaxy (MBE), which provides excellent uniformity and reproducibility.

Features:

- Ultra-High Sensitivity (880V/AT)
- Low current requirement
- Very low power consumption
- Extended operating temperature range
- Small linearity error of the Hall voltage
- Plastic miniature package SOT-143 for surface mounting or SIP (Through Slot)
- Wide measuring range (0.1 μ T-3T)



Applications:

- Magnetic field measurement
- Low temperature applications
- Current and power measurement
- Control of brushless DC motors
- Microswitches
- Position sensors
- Speed and RPM sensing



1. Model

CYSJ15A Hall Sensor is fabricated from AlGaAs/InGaAs/GaAs-2DEG (two-dimensional electron gas) heterojunction semiconductor.

2. Absolute Maximum Ratings

Parameter	Symbol	Rating	Unit
Control Voltage	V_c	5	V
Control Current	I_c	1.4	mA
Power Dissipation	P_D	7	mW
Operating Temperature	T_{op}	-100 ~ +200	$^{\circ}$ C
Storage Temperature	T_s	-100 ~ +200	$^{\circ}$ C
Soldering Temperature [#]	T_{sol}	260	$^{\circ}$ C

[#]Soldering time: 10 seconds

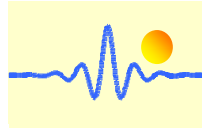

3. Electrical Characteristics

Parameter	Symbol	Test Condition	MIN	TYP	MAX	Unit
Output Hall Voltage	V_H	$I_c=1\text{mA}$, $B=100\text{mT}$	74	85	96	mV
Residual Ratio* ¹	V_{HO}/V_H	$I_c=1\text{mA}$	-10	-	+10	%
Residual Ratio* ¹	V_{HO}/V_H	$I_c=0.5\text{mA}$	-5	-	+5	%
Input Resistance	R_{IN}	$I_c=0.1\text{mA}$, $B=0\text{ mT}$	3.1	3.5	4.1	k Ω
Output Resistance	R_{OUT}	$I_c=0.1\text{mA}$, $B=0\text{ mT}$	3.1	3.5	4.1	k Ω
Temperature Coefficient of Hall Voltage* ²	α	$I_c=1\text{mA}$, $B=100\text{mT}$ ($T_1= -100\text{ }^\circ\text{C}$, $T_2=150\text{ }^\circ\text{C}$)	-0.05	-0.08	-0.13	%/ $^\circ\text{C}$
Temperature Coefficient of Input Resistance* ³	β	$I_c=1\text{mA}$, $B=0\text{ mT}$ ($T_1= -100\text{ }^\circ\text{C}$, $T_2=150\text{ }^\circ\text{C}$)	-	0.3	0.4	%/ $^\circ\text{C}$
Linearity of Hall Voltage* ⁴	γ	$I_c= 1\text{mA}$, $B_1=60\text{mT}$, $B_2=500\text{mT}$	-	1	1.5	%

$$* 1 \quad \text{Residual Ratio} = \frac{V_{HO}(B=0\text{mT})}{V_H(B=100\text{mT})}$$

$$* 2 \quad \alpha = \frac{I}{V_H(T_1)} \times \frac{V_H(T_2) - V_H(T_1)}{T_2 - T_1} \times 100$$

$$* 3 \quad \beta = \frac{1}{R_{IN}(T_1)} \times \frac{R_{IN}(T_2) - R_{IN}(T_1)}{T_2 - T_1} \times 100$$

$$* 4 \quad \gamma = \frac{K_H(B_2) - K_H(B_1)}{K_H(B_2) + K_H(B_1)} \times 200$$

$$K_H = \frac{V_H}{IB}$$

V_{HO} : Offset Voltage

B : Magnetic Flux Density

T_1, T_2 : Ambient Temperature

K_H : Current Sensitivity

4. Part Numbers and Ordering Information

Package	P/N	Mark	Packing	Temperature range
SOT-143	CYSJ15A-S	15A	3000 units/reel	-100 $^\circ\text{C}$ ~ +200 $^\circ\text{C}$
SIP/2.7x2.35x0.95mm	CYSJ15A-T	15A	500 units/pack	-100 $^\circ\text{C}$ ~ +200 $^\circ\text{C}$

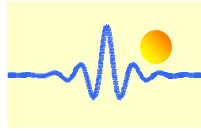

5. Shape of the Hall sensor

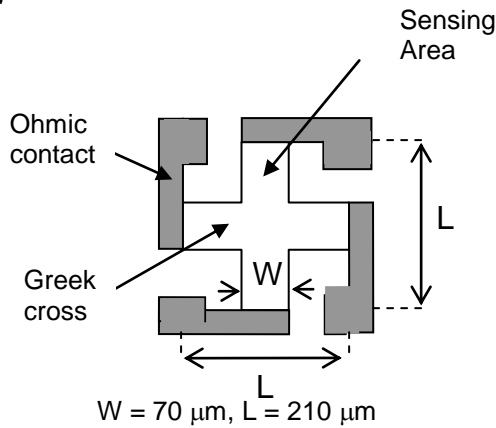

6. Typical Characteristics

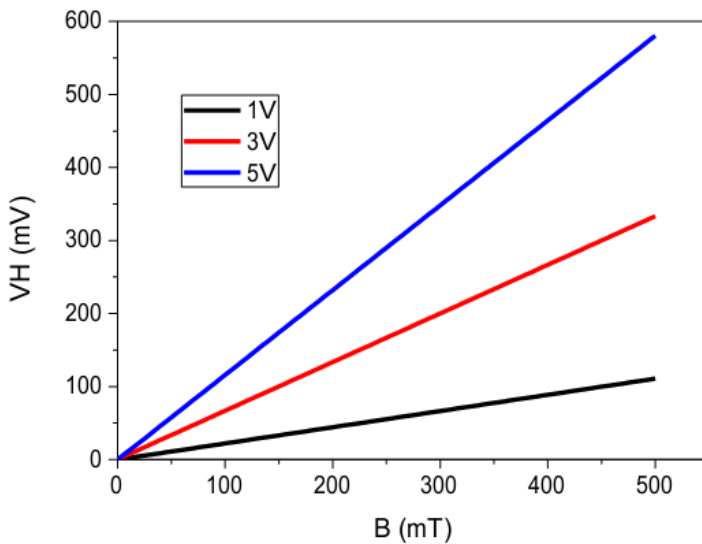

Output Hall Voltage versus magnetic field under supplying 1V, 3V and 5V across the inputs of Hall Sensor

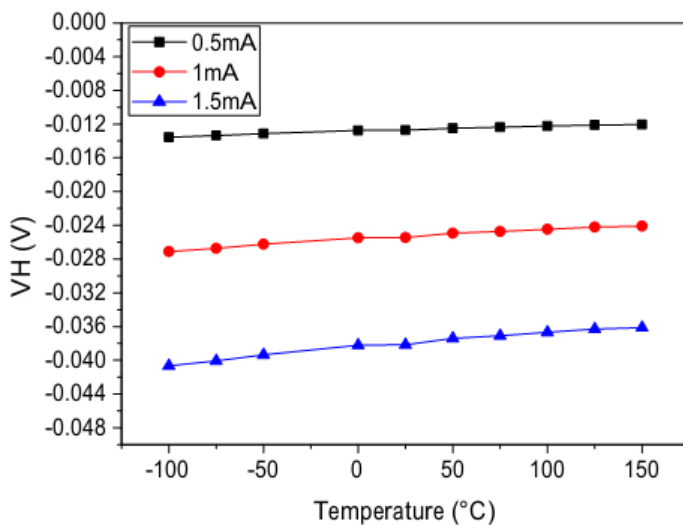

Output Hall Voltage versus temperature under supplying bias currents of 0.5mA, 1mA and 1.5mA across the inputs of Hall Sensor and at 30mT magnetic field

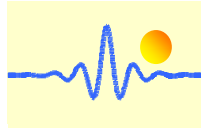

7. Outline drawings (unit: mm)

7.1. Package SOT 143 (Surface Mount)

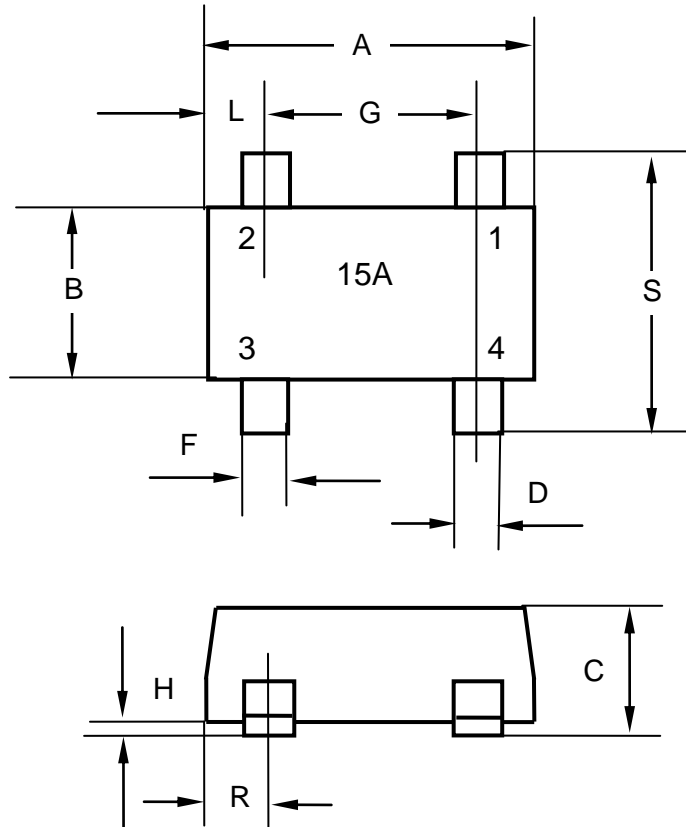

SOT 143 packaged Hall Sensor

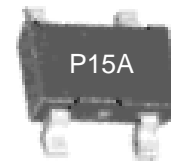

B ↓ Magnetic Field

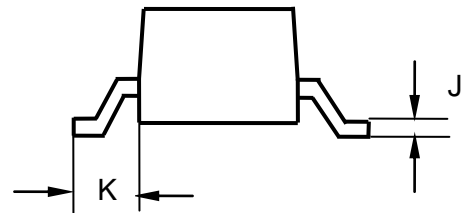

Terminal Connection

Terminal No.		Polarity
1	Input	(±)
2	Output	(±)
3	Input	(⊖)
4	Output	(⊖)

SOT 143 Package Dimensions

	Min (mm)	Max (mm)
A	2.8	3.0
B	1.4	1.6
C	1.0	1.3
D	0.4	0.5
F	0.4	0.5
G	1.8	2.0
H	0.0	0.1
J	0.1	0.15
K	0.3	0.4
L	0.5	0.6
R	0.5	0.6
S	2.7	3.1

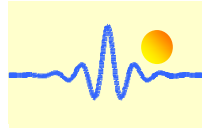

7.2. Package SIP (Through Slot)

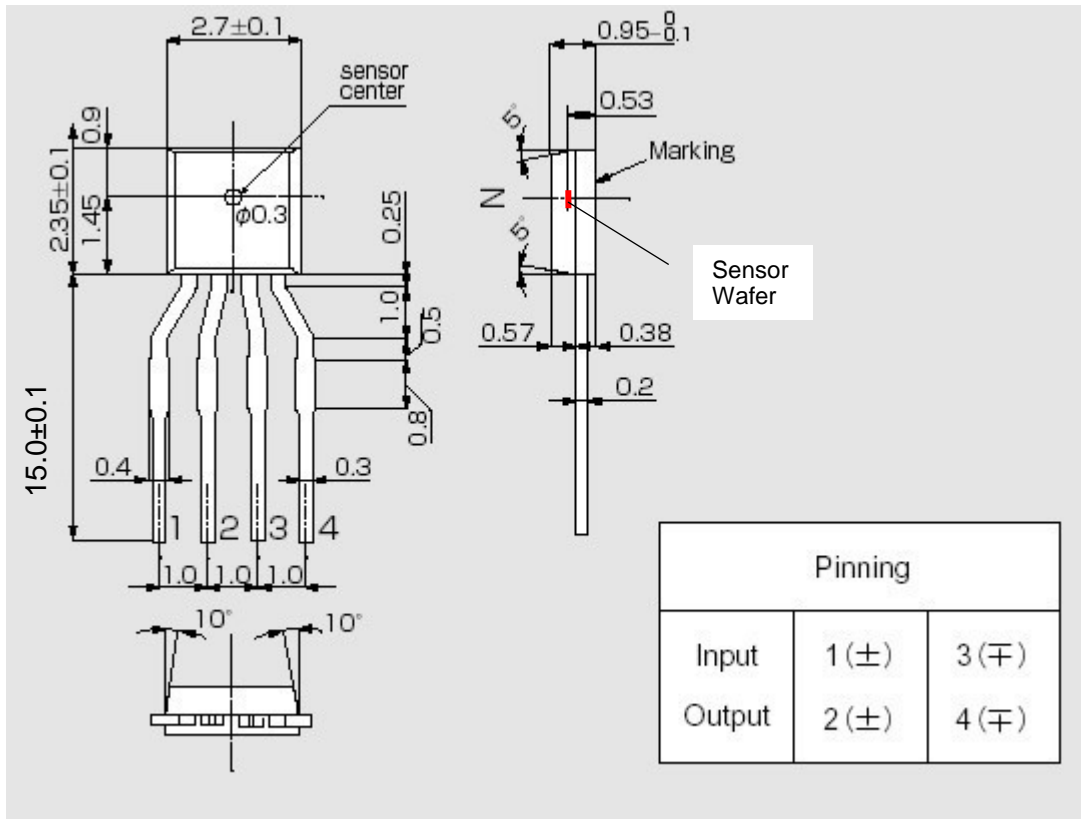

8. Connection

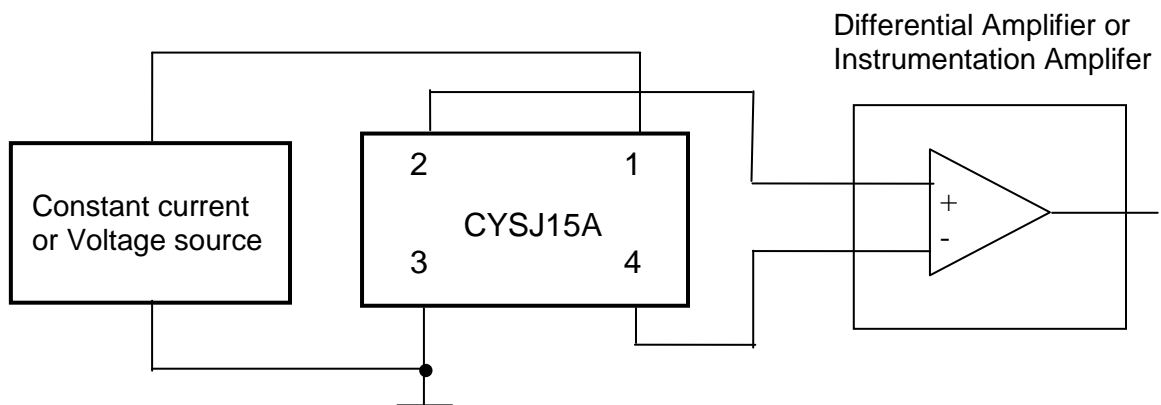

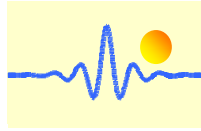

9. Application Notes

The Hall voltage V_H can be positive and negative. But if one connects the sensor as follows:

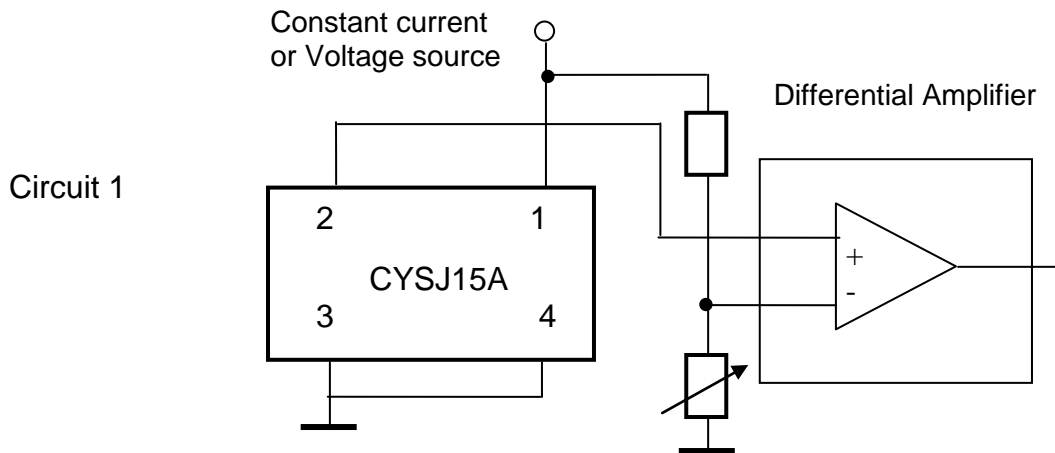

- Pin 1: positive input voltage V_+ , for instance +5VDC.
- Pin 3: GND
- Pin 2: OUTPUT
- Pin 4: GND

One can only measure the positive voltage at the pin 2. This means that the output voltage at zero magnetic field is not zero. This voltage is called as offset voltage. The output voltage in this case is not equal to the Hall voltage. The output voltage is equal to the sum of offset voltage and Hall voltage.