

CYD3661 Micropower High-Sensitivity Hall Effect Sensors (Omni-polar)

The CYD3661 is high-sensitive, pole independent Hall-Effect switches with a latched digital output. It is very suitable for operation in battery-operated, hand-held equipment such as cellular and cordless phone, PDA, pagers palmtop computers. The built-in dynamic offset cancellation of pre-amplifier stage achieves optimal symmetrical magnetic sensing. The supply voltage range is from 2.4V to 5.5V and the max output current is 5mA.

Unlike other Hall-effect switches, either a north or south pole of sufficient strength will turn the output on. In the absence of a magnetic field, the output is off. The polarity independence and minimal power requirement allows this device to easily replace reed switches for superior reliability.

APPLICATIONS

- Cover detector
- Battery-operated
- Hand-held equipment
- Door sensors

FEATURES

- Micro-power operation, **Omni -polar**
- Extreme low power dissipation
- Built-in dynamic offset cancellation
- Thin SOT package
- ESD protected to 5KV
- High balance and low thermal drift magnetic sensing
- **ROHS compliant**

ABSOLUTE MAX. RATINGS (T_A=25°C)

Parameter	Symbol	Condition	Value	Units
Supply voltage	V _{DD(MAX)}		7	V
Allowable power dissipation	P _d		300	mW
Storage temperature	T _s		-55 ~ +150	°C
Operating temperature	T _a		-40 ~ +85	°C
Output current	I _{out}		5	mA

ELECTRICAL CHARACTERISTICS T_A=25°C, V_{DD}=2.75V

Parameter	Symbol	Test condition	Value			Units
			Min.	Typ.	Max.	
Supply voltage	V _{DD}		2.4	2.75	5.5	V
Output sink voltage	V _{DS(ON)}	I _{out} =1mA, V _{DD} =2.75V	-	0.1	0.25	V
Supply current	I _{AWK}	Awake, V _{DD} =2.75V	-	3	5	mA
	I _{SLP}	Sleep, V _{DD} =2.75V		2	4	µA
	I _{AVG}	V _{DD} =2.75V		2.75	5.25	µA
Awake time	T _{AWK}	Operating		45	90	µS
Period	T _P	Operating		180	360	mS
Duty cycle				0.025		%

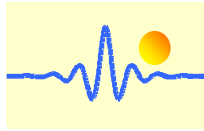

Magnetic Characteristics $T_A=25^\circ\text{C}$, $V_{DD}=2.75\text{V}$

Parameter	Symbol	Test Condition	Value			Units
			Min.	Type.	Max.	
Operation Point	B_{OP}	S pole operation point	-	± 35	± 70	GS
Release Point	B_{RP}	S pole release point	± 10	± 25	-	GS
Hysteresis	B_H	$ B_{OP} - B_{RP} $		10		GS

BLOCK DIAGRAM

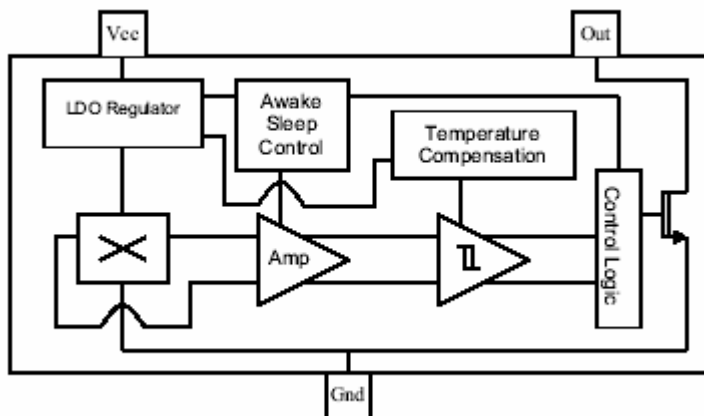

Magnetic Flux Density in Gauss

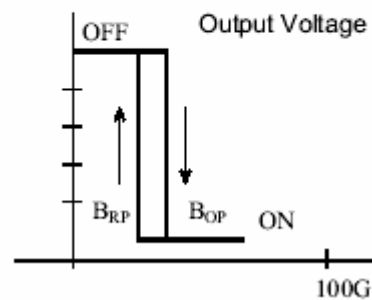

The micro power operation is realised by an awake/sleep timing control as shown in the following figure. Internal timing circuitry activates the sensor for $45\mu\text{s}$ and deactivates it for the remainder of the period (180ms). A short awake time allows for stabilization prior to the sensor sampling and data latching on the falling edge of the timing pulse. The output during the sleep time is latched in the last sampled state. The supply current is not affected by the output state.

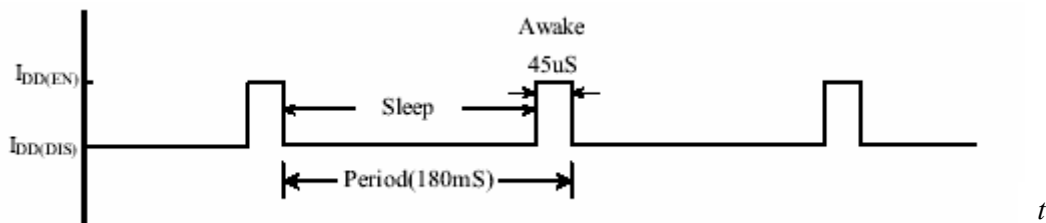

Output sink voltage versus temperature

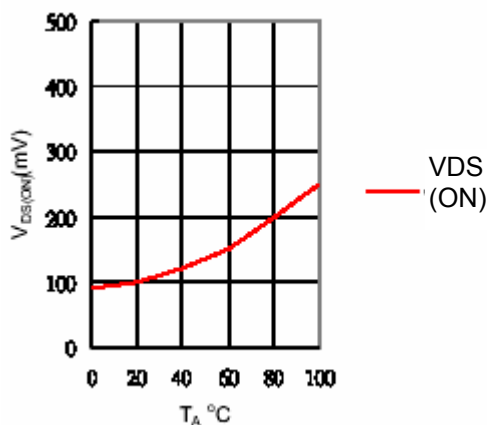

B_{OP} , B_{RP} Versus Temperature

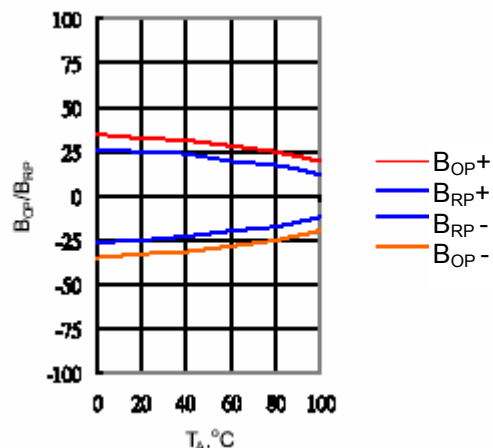

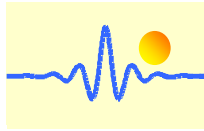

Package Outline

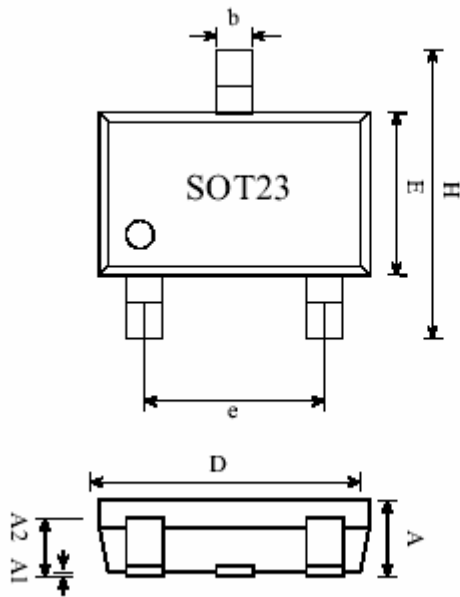

Sensor Location

Bottom view

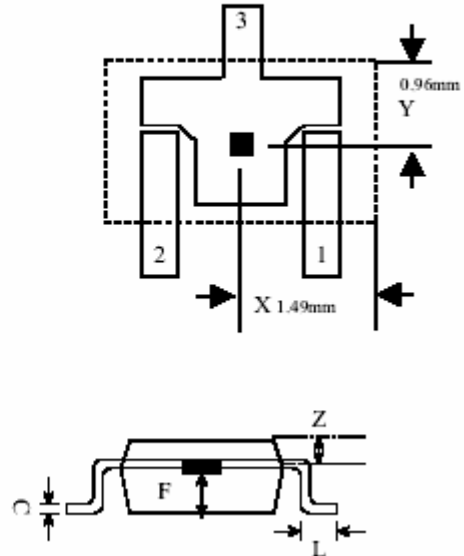

SYMBOLS	DIMENSIONS IN MILLIMETERS(mm)		
	MIN	NOM	MAX
A	1.00	1.10	1.30
A1	0.00	-	0.10
A2	0.70	0.80	0.90
b	0.35	0.40	0.50
C	0.10	0.15	0.25
D	2.70	2.90	3.10
E	1.60	1.80	2.00
F	0.55	0.60	0.65
H	2.60	2.8	3.00
e	1.7	1.9	2.1
L	0.20	-	-
SENSOR LOCATION			
X	-	0.96	-
Y	-	1.49	-
Z	-	0.50	-

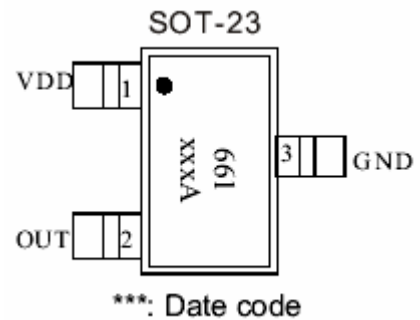

Pin Description

Name	Pin	Description
VDD	1	DC power supply
OUT	2	Output pin
GND	3	DC ground



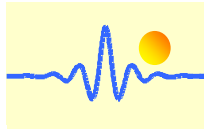

APPLICATION CIRCUITS

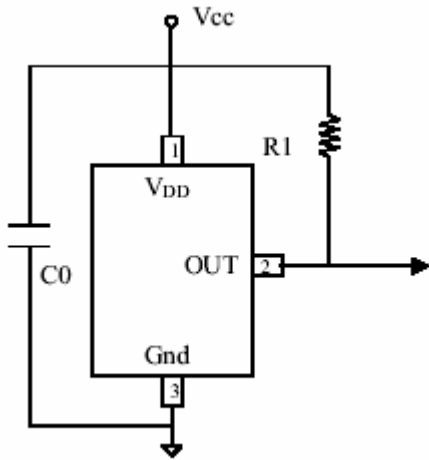

Solder-Pad Layout

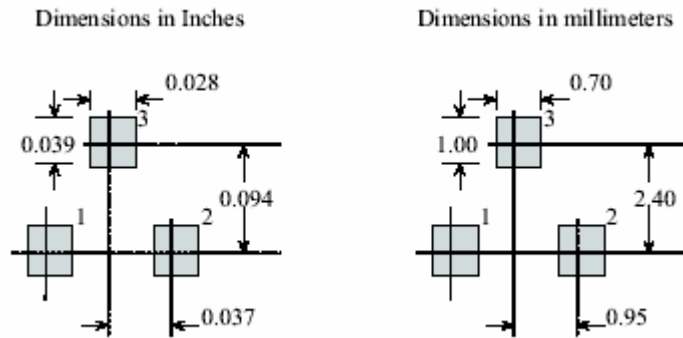

NOTE:
C0: 0.1 μ F decoupling capacitor
R1: >470 k Ω is recommended

APPLICATION NOTES

Magnet Characteristic

Magnetization direction

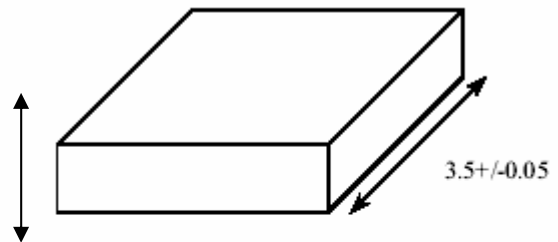

Dimensions (mm)

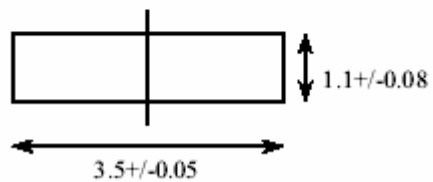

Recommended Sensing Location

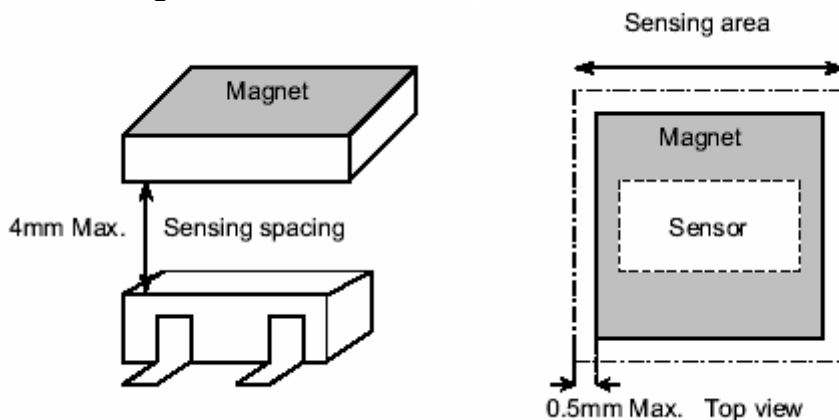

Ordering Information

Part no.	Mark	Package/Packing	Temperature range
CYD3661	661	SOT-23 / 3000units/reel	-40°C ~ +85°C