

Hall Effect Gear Tooth Speed Sensors CYGTS288

Hall Effect gear tooth sensors CYGTS288 are applied to the non-contact speed measurement of rotational gears. The measuring range is 1-20000rpm and the output square-wave signal can be directly connected with TTL, CMOS electric circuits and general tachometers to constitute the tachometric measuring and control systems.

The CYGTS288 sensors use the standard cylinder structure and have advantages of the waterproofing, dustproof, guards against the greasy dirt. They can reliably work in adverse circumstances, specially are suitable for industry control and military applications.

Measuring Principle

CYGTS288 gear tooth sensors use a magnetically biased Hall Effect integrated circuit to accurately sense rotational movement of ferrous metal gears. This specially designed integrated circuit with bias magnet is sealed in metal package for physical protection and cost effective installation.

Thanks to the advanced Hall Effect measurement technology, these sensors can distinguish the addendum and tooth valley of the rotated gear and transform them to a square-wave output signal. Corresponding to a pair of addendum and tooth valley the sensor outputs a period of square-wave signal (namely conversion ratio $K=1$). The Hall Effect gear velocity sensors can be used to measure gears with a modulus $\geq 1\text{mm}$.

These Units function under power supply from 4.5VDC to 30VDC. Output is digital, current sinking (OC or RC). Reverse polarity protection is normally integrated. The sensor will not be damaged if power is inadvertently wired backwards.

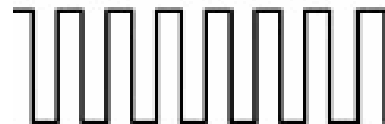

Features

- Sensing ferrous metal targets
- Digital current sinking output (OC or RC)
- Good signal-to-noise ratio
- Excellent low speed performance
- Output amplitude not dependent on RPM
- Reverse polarity protection and output short circuit protection

Applications

- Camshaft and crankshaft speed and position
- Transmission speed
- Tachometers, counters
- Anti-skid/traction control
- Sprocket speed
- Chain link conveyor speed/distance
- Stop motion detector
- High speed low cost proximity

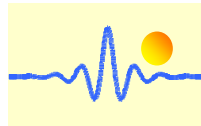

General Specifications

Rated sensing distance	≤3mm (determined by reference target wheel)
Response frequency	1Hz ~ 20kHz
Measuring range	1~20000 rpm (using 60P/R gear)
Output signal	Square wave, duty cycle 50%±20%
Working display	LED
Protection function	Working voltage polarity protection and output short-circuits protection
Operating Temperature Range	-40°C ~ +125°C
Environmental protection performance	waterproofing, dustproof, guards against greasy dirt, anti-50G machinery impact

Electric Properties

Parameter	Value (range)
Power supply (DC) Vcc(V)	4.5 ~ 30
Static consumption current Is (mA)	≤ 30
Max. output current Iomax (mA)	100
High output voltage VOH (V)	Vcc – 0.5
Low output voltage VOL (V)	≤ 0.6
Rise time tr (μs)	≤ 2
Fall time tf (μs)	≤ 2
Output polarity.	NPN or PNP
Output Type	OC or RC
Screw size (mm)	M12 x 1, M16 x 1, M18 x 1

Requirement of Measuring Target Wheel

Gear modulus	Tooth profile	Tooth thickness	Gear material
≥1mm	helical gear, Trapezoidal column spur gear	≥3mm	ferromagnetic material

Reference Target Wheel (for sensor calibration)

Optimum sensor performance is dependent on the following variables which must be considered in combination:

- Target material, geometry, and speed
- Gap between sensor and target
- Ambient temperature
- Magnetic material in close proximity.

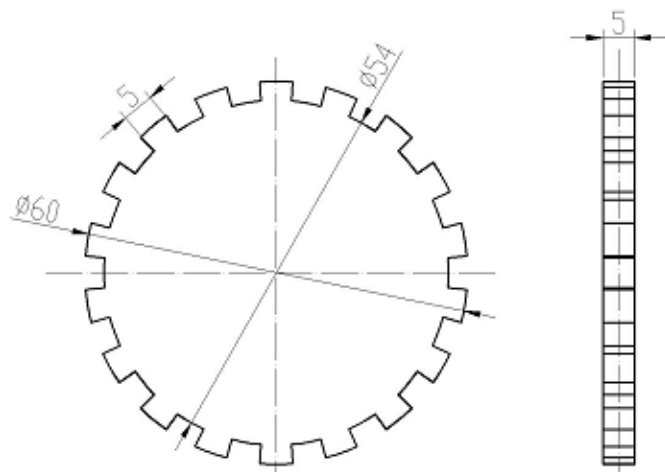

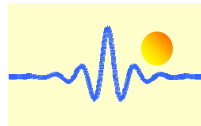

Mounting Dimensions (for reference only)

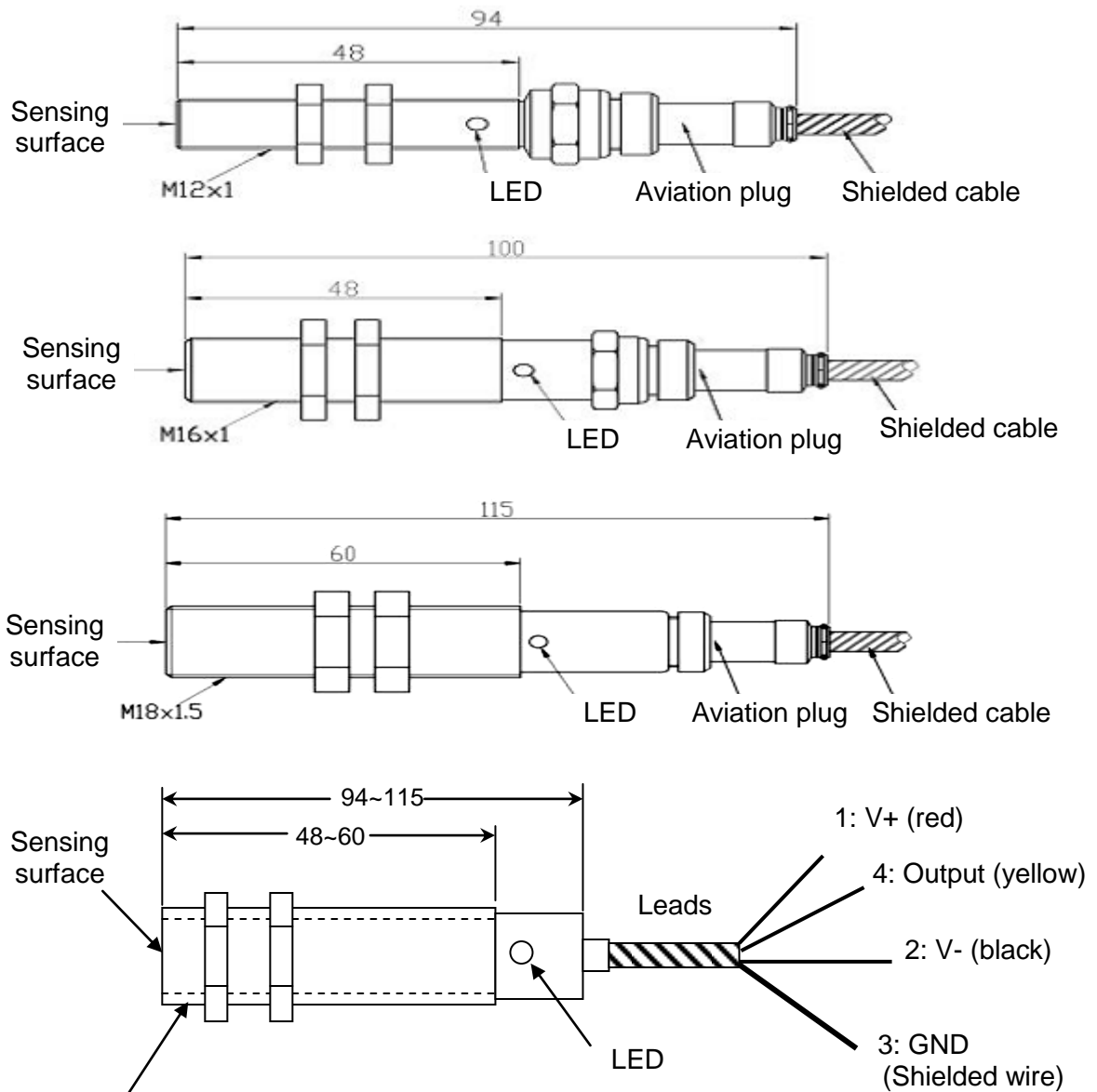

CYGTS288-NO12	M12x1
CYGTS288-NR12	
CYGTS288-PO12	
CYGTS288-PR12	
CYGTS288-NO16	M16x1
CYGTS288-NR16	
CYGTS288-PO16	
CYGTS288-PR16	
CYGTS288-PR18	M18x1

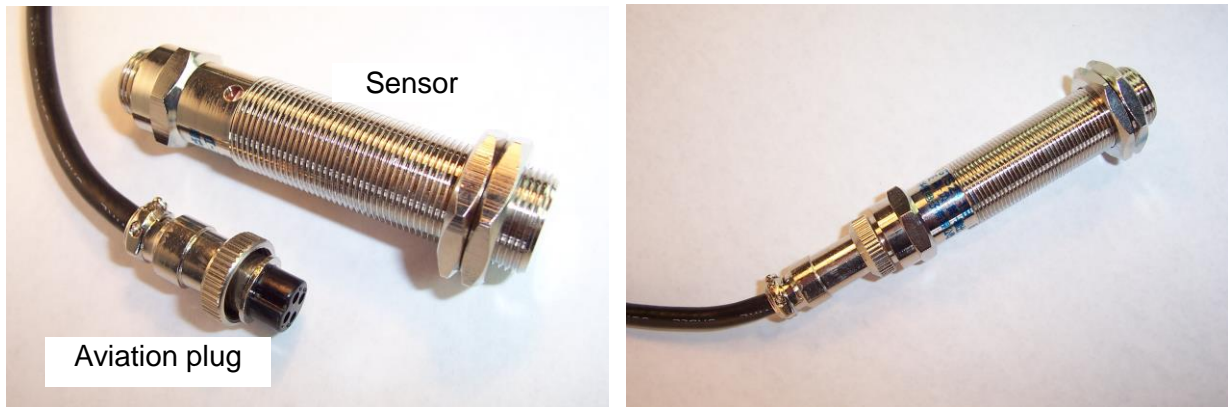
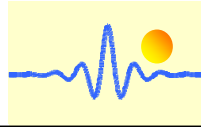

Application Notes

Installation

The sensor should be installed in the correct way. Please use the delivered screw to fix the sensor on the instalment hole. The attachment system must be non-magnetic material (copper, aluminium, stainless steel and so on). The sensing surface of the sensor should be oriented/adjusted to the tooth face. The space between the tooth face and the sensing surface of the sensor should not be bigger than the maximum measuring distance.

Gear Selection

The suitable gear selection has a very tremendous influence to the speed measurement because the sensor measuring object is a gear.

First, the biggest affect to the measurement is the gear modulus. The right figure shows the relation between the modulus and measuring distance. Therefore, a bigger gear modulus should be selected in the condition permission situation ($m \geq 1$).

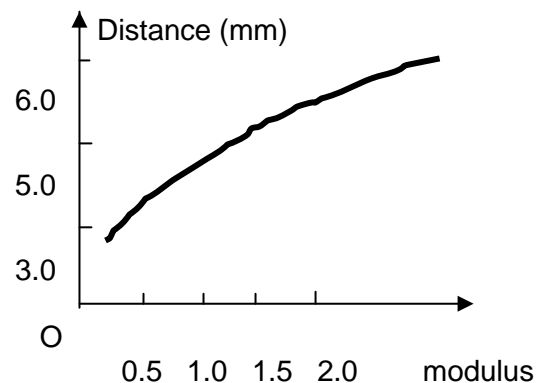

Next, the gear active status can also have certain influence. Generally speaking, the measured gear is already used in the machine, or it is perhaps a special-purpose measuring gear. The gear can be directly fixed on the axis (axis transmission) or through other gear meshing rotations (tooth transmission). When the gear is in a meshing rotation, the tooth face attrition can cause the change of the duty cycle of the output signal. Therefore a special-purpose measuring gear should be directly installed on the measured axis when the duty cycle has a high requirement.

In addition, a smaller measuring distance should be used if the revolution axis has a bigger radial free movement. In this case magnetic material with high permeability should be used to make the target gear.

The measuring range changes with the teeth number N and can be determined by

$$\text{Min. speed: } \gamma_{\min} = 60/N \text{ (rpm)}$$

$$\text{Max. speed : } \gamma_{\max} = 1.2 \times 10^6 / N \text{ (rpm)}$$

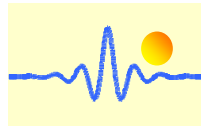

Connection

The CYGTS288 series product uses the single-point ground for electromagnetic shield. The sensor case is connected to the shield leads. The user is supposed to connect the shield leads to system ground at the receiving input, see the concrete wiring shown in the right figure.

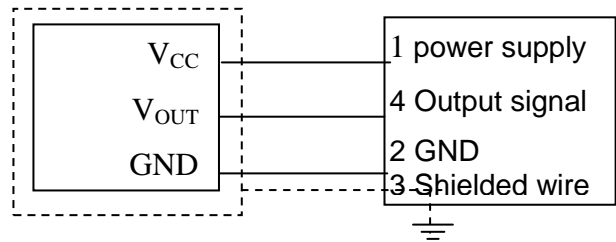

Circuits of OC and RC Output:

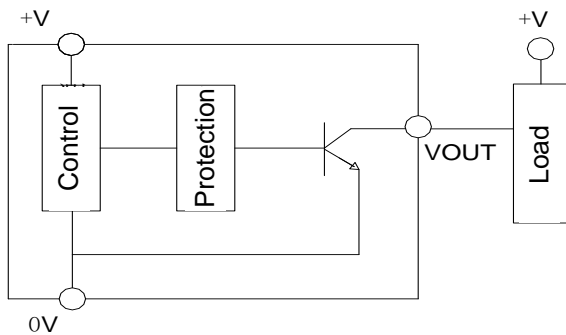

NPN (OC) Output

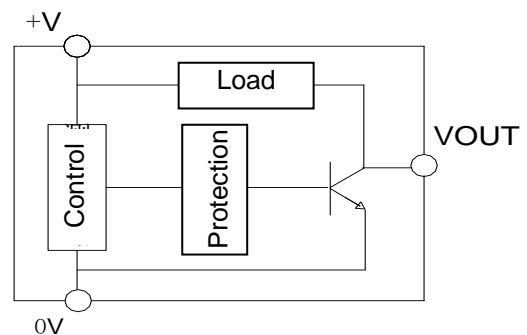

NPN (RC) Output

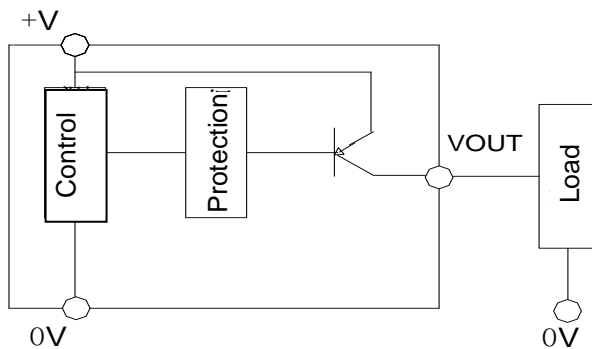

PNP (OC) Output

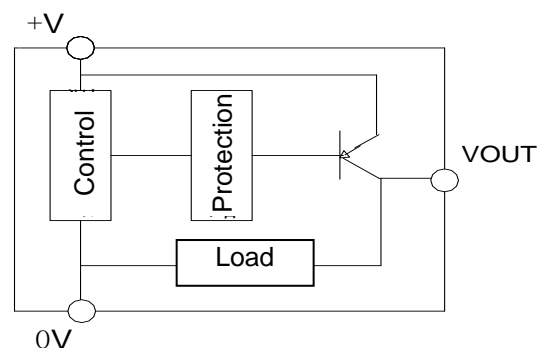

PNP (RC) Output

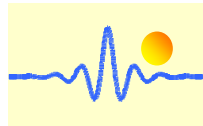

If there is stronger electromagnetic interference or the distance between sensor and the measuring instrument is farther, an OC output (open collector) is suggested to use. In this case a pull-up resistor ($1k\Omega \sim 10k\Omega$) should be connected to the sensor output circuit (between power supply + and output).

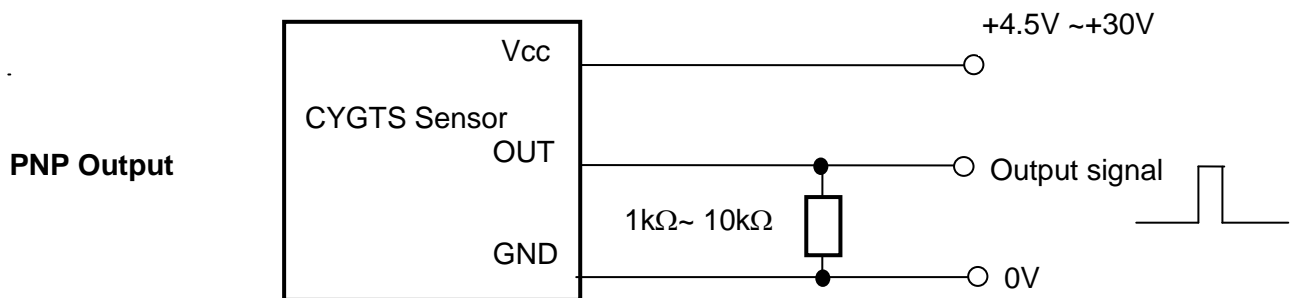
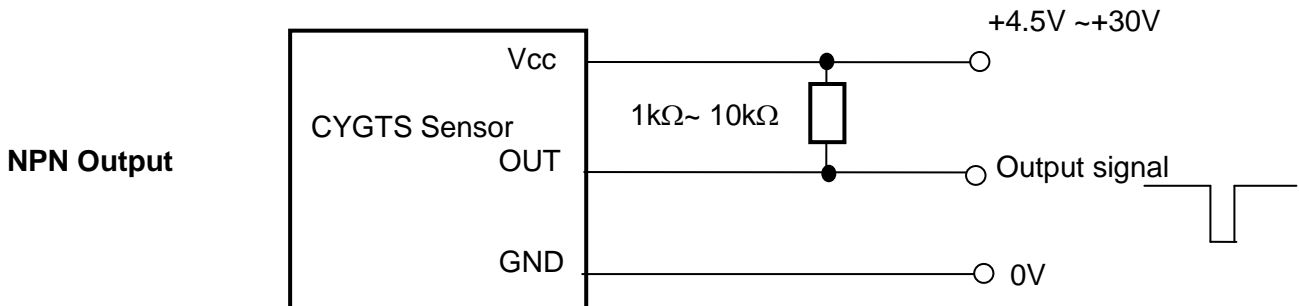

Order Information

Part number of sensor CYGTS288

CYGTS288	-	x	O	M
(1)		(2)	(3)	(4)

(1)	(2)	(3)	(4)
Series name	Output pole	Output type	Screw
CYGTS288	x=N: NPN x=P: PNP	O: OC R: RC	12: M12x1mm 16: M16x1mm 18: M18x1mm

Example: CYGTS288-NO12, Hall Effect Gear Tooth Sensor CYGTS288 with Power supply 4.5 ~ 30VDC
NPN Output, OC open collector output
M12x1mm screw