

Closed Loop Hall Current Sensor CYHCS-B100

This Hall Effect current sensor is based on closed loop compensating principle and can be used for measurement of DC and AC current, pulse currents etc. The output of the transducer reflects the real wave of the current carrying conductor.

Product Characteristics	Applications
<ul style="list-style-type: none">• Excellent accuracy• Very good linearity• Small size and encapsulated• Less power consumption• Current overload capability	<ul style="list-style-type: none">• Photovoltaic equipment• General Purpose Inverters• AC/DC Variable Speed Drivers• Battery Supplied Applications• Uninterruptible Power Supplies (UPS)• Switched Mode Power Supplies

ELECTRICAL CHARACTERISTIC

	CYHCS-B100-6A	CYHCS-B100-15A	CYHCS-B100-25A	CYHCS-B100-50A
Nominal current	6A	15A	25A	50A
Measuring range	18A	45A	75A	150A
Measuring resistance	100Ω	50Ω	50Ω	25Ω
Number of secondary turns	960±1	1200±1	2000±2	2000±2
Nominal analogue output voltage	+2.5VDC ± (0.625V±0.5%)			
Supply voltage	+5VDC ±5%			
Galvanic isolation	50Hz, 1min, >3kV			
Impulse withstand voltage	1.2/50μs, >8kV			
Creepage distance	>15.5mm			

ACCURACY DYNAMIC PERFORMANCE

Zero offset voltage at +25°C	2.5±0.5%	V DC
Thermal drift of offset voltage (-40°C ~ +85°C)	Typ.: ±0.08, Max.: ±0.20	mV/°C
Linearity	≤0.1	%FS
Accuracy	±0.7	%
di/dt accuracy followed	>50	A/μs
Response time	<500	ns
Bandwidth (-1db)	DC ~ 200	kHz

GENERAL CHARACTERISTIC

Operating temperature	-40 ~ +85	°C
Storage temperature	-40 ~ +125	°C
Current consumption	10	mA

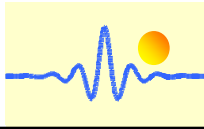

Dimensions (mm)

+ +5V
0 0V
OUT: Output

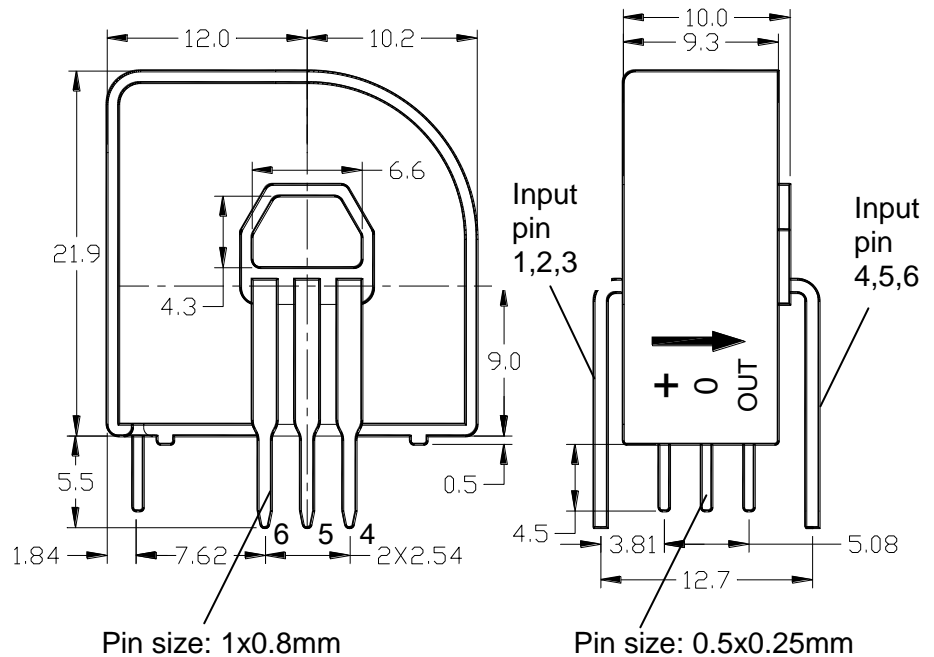

Wiring diagram

Number of Primary turns	Nominal current (A)	Output voltage (V)	Primary resistance (mΩ)	Primary inductance (μH)	Input Pin Connection
1	±6 (±15,±25,±50)	2.5±0.625	0.18	0.013	
2	±3 (±7.5,±12.5,±25)	2.5±0.625	0.81	0.05	
3	±2(±5,±8.3, ±16.6)	2.5±0.625	1.62	0.12	

Application Notes

There are two inputs methods: 1) Cable Input using the sensor hole; 2) PCB Input using the input pins. You should only use one of these input models.

For the cable input model the current cable should be passed through the hole of the sensor. Taking the sensor CYHCS-B100-6A as example, the nominal current is 6A if the cable is passed through the hole one time. The nominal current is 3A or 2A if the cable is wired through the hole 2 or 3 times. In this input model please don't use the input pins.

For PCB input model one should wire the sensor according to the input pin connection shown in the above table. The 3 wiring diagrams correspond to the number of primary turns 1, 2 and 3. In this input model please don't use the hole of sensor as input.

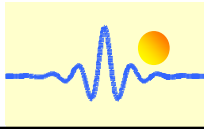

Relation between Input Current and Output Voltage

Take the sensor CYHCS-B100-25A as sample, the relation between the input current and output voltage is shown in the table 1, Fig.1 and Fig. 2

Table 1. Relation between the input current and output voltage

Input current (A)	-75	-50	-25	-12.5	0	12.5	25	50	75
Output voltage (V)	0.625	1.25	1.875	2.188	2.5	2.813	3.125	3.75	4.375

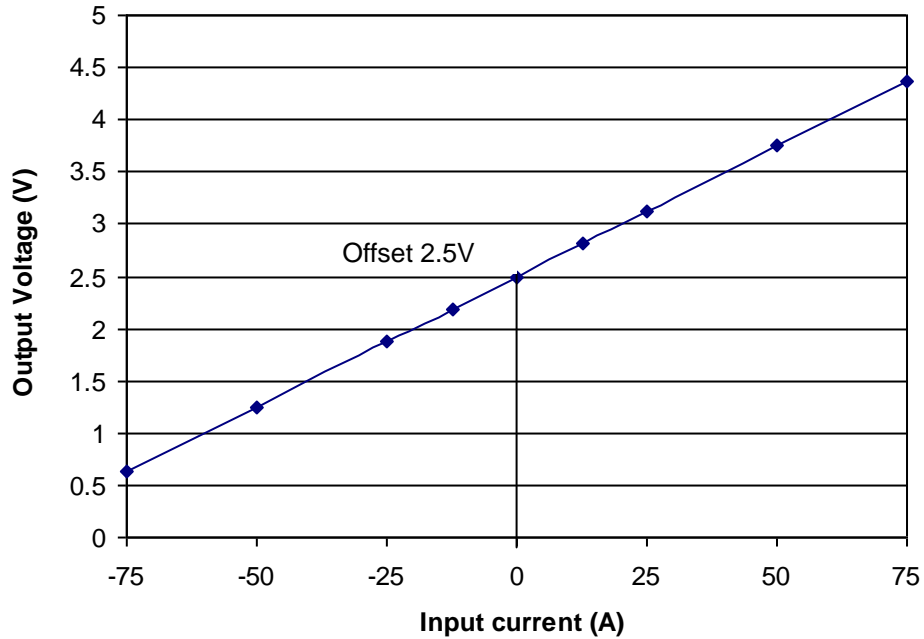

Fig. 1 Relation between the input current (DC) and output voltage (DC)

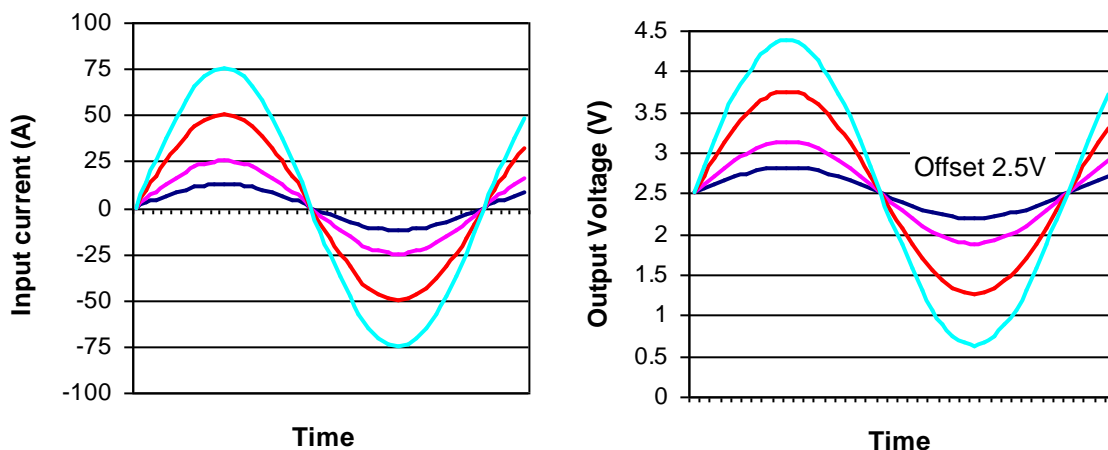

Fig. 2 Relation between the input current (AC) and output voltage (AC)