



Hall Effect DC Current Sensor CYHCS-C1TC

This Hall Effect current sensor is based on open loop compensating principle and designed with a split core and a high galvanic isolation between primary and secondary circuits. It can be used for measurement of AC current, pulse currents etc. The output of the transducer reflects the real wave of the current carrying conductor.

Product Characteristics	Applications
<ul style="list-style-type: none">• Excellent accuracy• Very good linearity• Using split cores and easy mounting• Less power consumption• Window structure• Electrically isolating the output of the transducer from the current carrying conductor• No insertion loss• Current overload capability	<ul style="list-style-type: none">• Photovoltaic equipment• Frequency conversion timing equipments• Various power supply• Uninterruptible power supplies (UPS)• Electric welding machines• Transformer substation• Numerical controlled machine tools• Electric powered locomotive• Microcomputer monitoring• Electric power network monitoring

Electrical Data

Primary Nominal RMS Current I_r (A)	Measuring Range (A)	DC Output Current (mA)	Aperture Diameter (mm)	Part number
50	100	4-20 \pm 1.0%	\varnothing 20	CYHCS-C1TC-50A-X
100	200			CYHCS-C1TC-100A-X
200	400			CYHCS-C1TC-200A-X
300	600			CYHCS-C1TC-300A-X
400	800			CYHCS-C1TC-400A-X
500	800			CYHCS-C1TC-500A-X

(X=3, V_{cc} = +12VDC \pm 5%; X=4, V_{cc} =+15VDC \pm 5%; X=5, V_{cc} =+24VDC \pm 5%)

Supply Voltage	V_{cc} =+12V, +15V, +24V \pm 5%
Current Consumption	I_c < 20mA + Output current
Galvanic isolation, 50/60Hz, 1min:	2.5kV
Load resistance:	10k Ω
Isolation resistance @ 500 VDC	> 500 M Ω

Accuracy and Dynamic performance data

Accuracy at I_r , T_A =25°C (without offset),	<1.0%
Linearity from 0 to I_r , T_A =25°C,	E_L <1.0% FS
Electric Offset Current, T_A =25°C,	4mA DC
Thermal Drift of Offset Voltage,	V_{ot} < \pm 0.005mA/°C
Response Time at 90% of I_p	t_r < 20ms
Load resistance:	80-450 Ω
Case Material:	PBT, heat resistant 125°C flame retardant



General Data

Ambient Operating Temperature,
Ambient Storage Temperature,

$T_A = -40^\circ\text{C} \sim +85^\circ\text{C}$
 $T_S = -55^\circ\text{C} \sim +125^\circ\text{C}$

PIN Definition and Dimensions

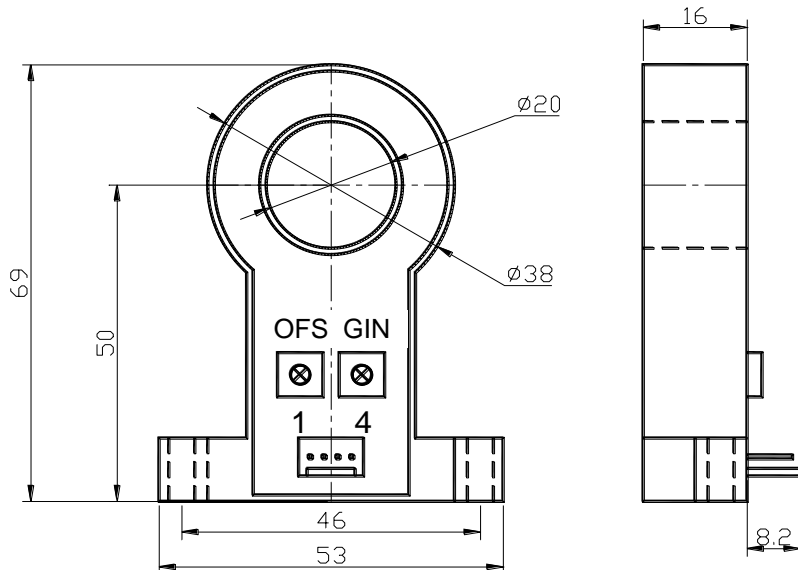

1(+): Vcc
2(G): GND
3(O): Output
4(G): GND

OFS: Offset Adjustment

GIN: Gain Adjustment

Connection

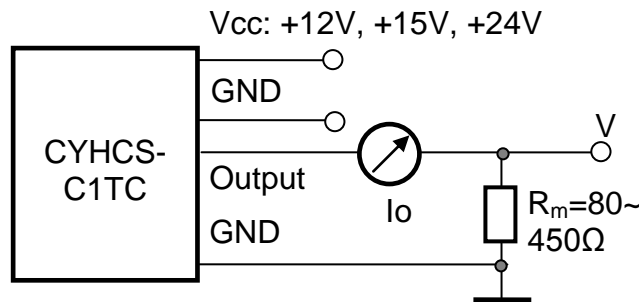

Notes:

1. Connect the terminals of power source, outputs respectively and correctly, never make wrong connection.
2. Two potentiometers can be adjusted, only if necessary, by turning slowly to the required accuracy with a small screwdriver.
3. The best accuracy can be achieved when the window is fully filled with bus-bar (current carrying conductor).
4. The in-phase output can be obtained when the direction of current of current carrying conductor is the same as the direction of arrow marked on the transducer