

## Split Core Hall Current Sensor CYHCS-C2S

This Hall Effect current sensor can be used for measurement of DC and AC current, pulsed currents etc. The output of the transducer reflects the real wave of the current carrying conductor.

Product Characteristics	Applications
<ul style="list-style-type: none"> <li>• Excellent accuracy</li> <li>• Very good linearity</li> <li>• Light in weight</li> <li>• Less power consumption</li> <li>• Window structure</li> <li>• Electrically isolating the output of the transducer from the current carrying conductor</li> <li>• No insertion loss</li> <li>• Current overload capability</li> </ul>	<ul style="list-style-type: none"> <li>• Frequency conversion timing equipments</li> <li>• Various power supply</li> <li>• Uninterruptible power supplies (UPS)</li> <li>• Electric welding machines</li> <li>• Numerical controlled machine tools</li> <li>• Electrolyzing and electroplating equipments</li> <li>• Electric powered locomotive</li> <li>• Microcomputer monitoring</li> <li>• Electric power network monitoring</li> </ul>

### Electrical Data/Input

Primary Nominal RMS Current $I_r$ (A)	Primary Current Measuring Range $I_p$ (A) at $V_{cc}=5V$	Aperture Diameter (mm)	Part number
50	$\pm 67.5$	21	CYHCS-C2S-50A
100	$\pm 135$	21	CYHCS-C2S-100A
200	$\pm 270$	21	CYHCS-C2S-200A
300	$\pm 405$	21	CYHCS-C2S-300A
400	$\pm 540$	21	CYHCS-C2S-400A
500	$\pm 675$	21	CYHCS-C2S-500A
600	$\pm 810$	21	CYHCS-C2S-600A

Supply Voltage  
Current Consumption  
RMS Voltage for 2.5kV AC isolation test, 50/60Hz, 1min,

$V_{cc} = +5V \pm 5\%$   
 $I_c < 25mA$   
 $V_{is} < 10mA$

### Electrical Data/Output

Output Voltage at  $I_r$ ,  $T_A=25^\circ C$ :  
Output Impedance:  
Load Resistor:

$V_{out} = V_{oe} \pm 1.5V$   
 $R_{out} < 150\Omega$   
 $R_L > 10k\Omega$

### Accuracy

Accuracy at  $I_r$ ,  $T_A=25^\circ C$  (without offset),  
Linearity from 0 to  $I_r$ ,  $T_A=25^\circ C$ ,  
Electric Offset Voltage,  $T_A=25^\circ C$ ,  
Magnetic Offset Voltage ( $I_r \rightarrow 0$ )  
Thermal Drift of Offset Voltage,  
Thermal Drift ( $-10^\circ C$  to  $50^\circ C$ ),  
Response Time at 90% of  $I_p$  ( $f=1k$  Hz)  
Frequency Bandwidth (-3dB),

$X < 1.0\%$   
 $E_L < 1.0\%$  FS  
 $V_{oe} = 2.5 \pm 1.0\%$   
 $V_{om} \leq \pm 15mV$   
 $V_{ot} < \pm 1.0mV/^\circ C$   
T.C.  $< \pm 0.1\%$  / $^\circ C$   
 $t_r < 7\mu s$   
 $f_b = 0-20$  kHz

### General Data

Ambient Operating Temperature,  
Ambient Storage Temperature,

$T_A = -40^\circ C \sim +85^\circ C$   
 $T_S = -55^\circ C \sim +125^\circ C$



## Relation between Input Current and Output Voltage

Take the sensor CYHCS-C2S-100A as sample, the relation between the input current and output voltage is shown in the table 1, Fig.1 and Fig. 2

**Table 1.** Relation between the input current and output voltage

Input current (A)	-135	-100	-75	-50	0	50	75	100	135
Output voltage (V)	0.475	1.0	1.375	1.75	2.5	3.25	3.625	4.0	4.525

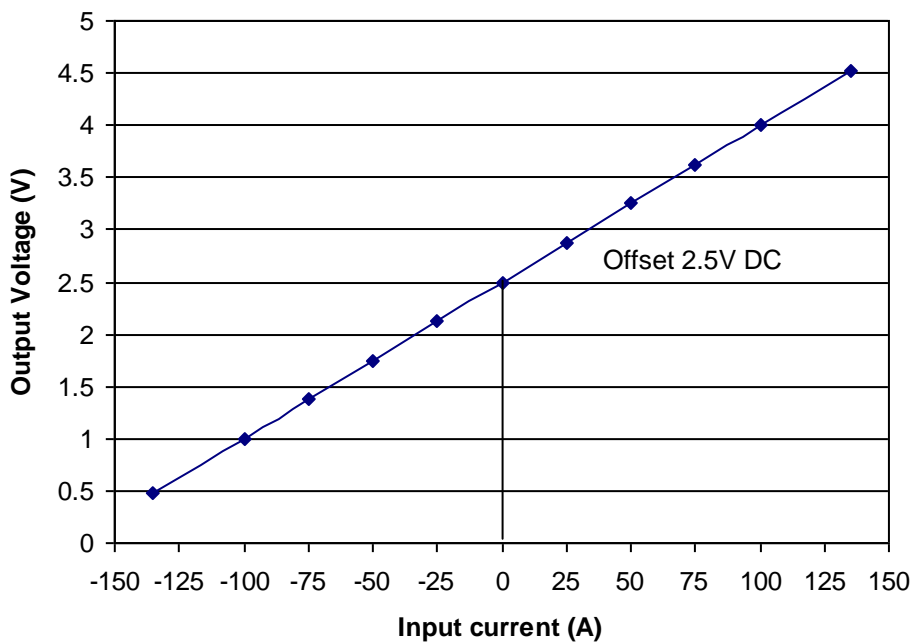

**Fig. 1** Relation between the input current (DC) and output voltage (DC)

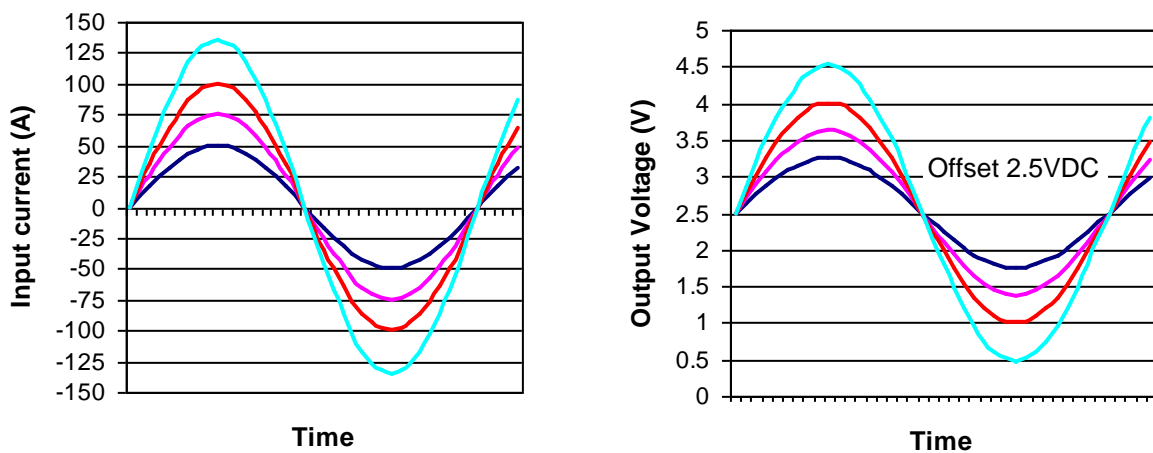

**Fig. 2** Relation between the input current (AC) and output voltage (AC)



## PIN Definition and Dimensions

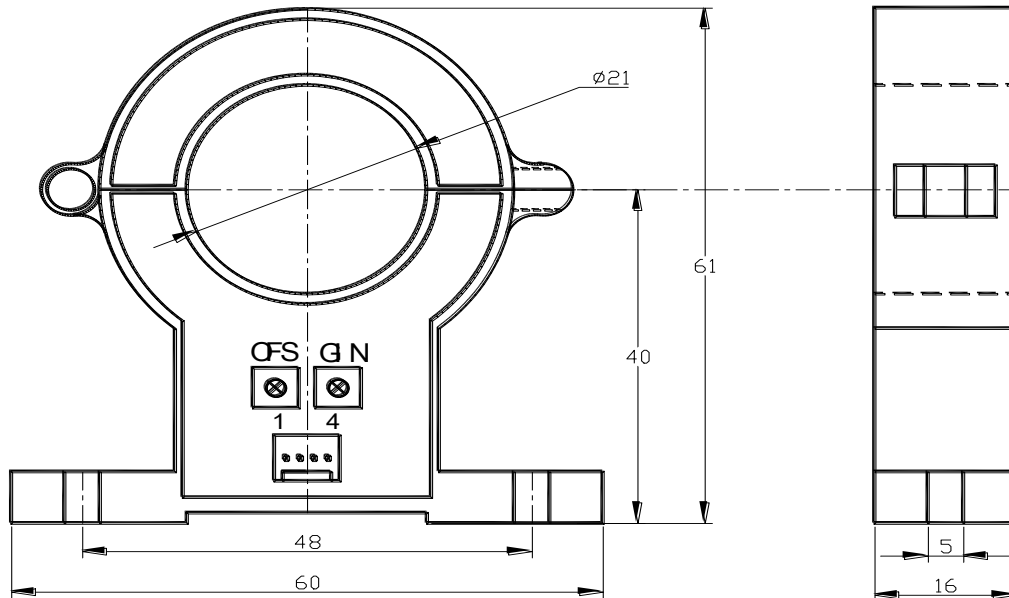

- 1: +5V DC
- 2: NC
- 3: OUTPUT
- 4: 0V (GND)



### Notes:

1. Connect the terminals of power source, outputs respectively and correctly, never make wrong connection.
2. Two potentiometers can be adjusted, only if necessary, by turning slowly to the required accuracy with a small screwdriver.
3. The best accuracy can be achieved when the window is fully filled with bus-bar (current carrying conductor).
4. The in-phase output can be obtained when the direction of current of current carrying conductor is the same as the direction of arrow marked on the transducer