

## Closed Loop Hall Current Sensor CYHCS-D1

This Hall Effect current sensor is based on closed loop compensating principle and designed with a high galvanic isolation between primary and secondary circuits. It can be used for measurement of DC and AC current, pulse currents etc. The output of the transducer reflects the real wave of the current carrying conductor.

Product Characteristics	Applications
<ul style="list-style-type: none"><li>• Excellent accuracy</li><li>• Very good linearity</li><li>• Less power consumption</li><li>• Current overload capability</li><li>• Goods temperature properties</li></ul>	<ul style="list-style-type: none"><li>• General Purpose Inverters</li><li>• AC/DC Variable Speed Drivers</li><li>• Battery Supplied Applications</li><li>• Uninterruptible Power Supplies (UPS)</li><li>• Switched Mode Power Supplies</li></ul>

### ELECTRICAL CHARACTERISTICS

Part number	CYHCS-D1-50A	CYHCS-D1-75A	CYHCS-D1-100A	CYHCS-D1-200A	CYHCS-D1-300A
Rated current (RMS)	50A	75A	100A	200A	±300A
Measuring range	±120A	±200A	±250A	±450A	±550A
Turn ratio	1:1000	1:1500	1:1000	1:2000	1:3000
Inner measuring resistance	80Ω±0.1%	80Ω±0.1%	40Ω±0.1%	40Ω±0.1%	40Ω±0.1%
Load resistance (at rated current)	≥10kΩ				
Rated output voltage	4V ±0.5%				
Supply voltage	±15 VDC ±5%				
Galvanic isolation	3kV RMS/50Hz/1min,				
Current consumption	<14mA				

### ACCURACY DYNAMIC PERFORMANCE

Zero offset voltage	±10mV
Thermal drift of offset voltage	±0.5mV/°C
Response time	<1.0μs
Accuracy	±0.5%
Linearity	≤0.1% FS
Bandwidth(-3dB)	DC ~ 150kHz

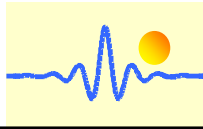

## GENERAL CHARACTERISTIC

Operating temperature	-40°C~+85°C
Storage temperature	-40°C~+125°C

## Dimensions (mm)

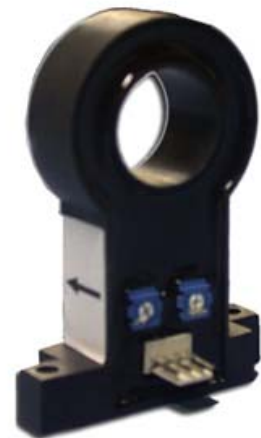
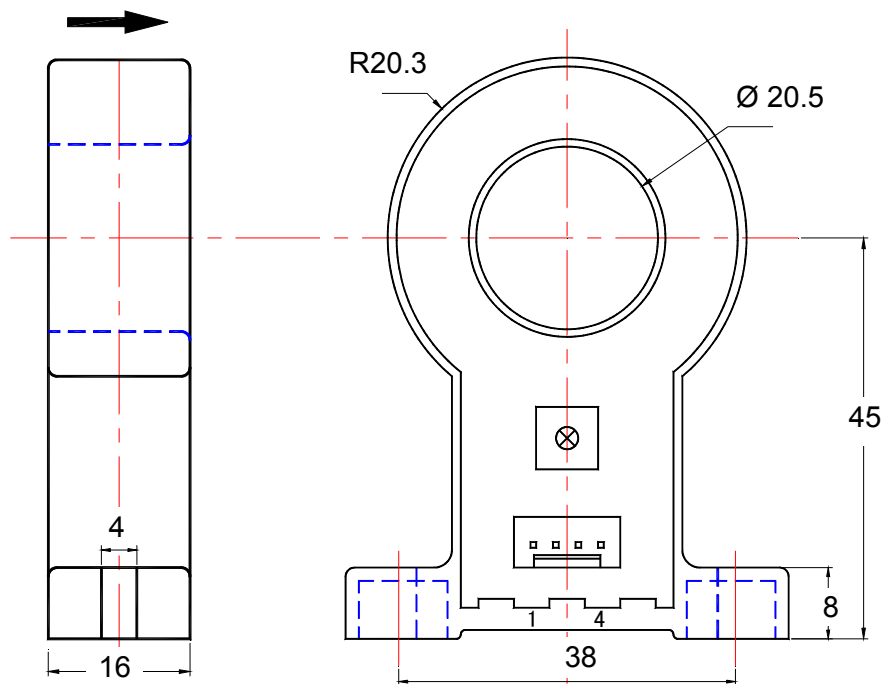

Terminal 1: +15V,  
Terminal 2: -15V,  
Terminal 3: Output,  
Terminal 4: ground

## Notes:

1. Connect the terminals of power source, outputs respectively and correctly, never make wrong connection.
2. Two potentiometers can be adjusted, only if necessary, by turning slowly to the required accuracy with a small screwdriver.
3. The best accuracy can be achieved when the window is fully filled with bus-bar (current carrying conductor).
4. The in-phase output can be obtained when the direction of current of current carrying conductor is the same as the direction of arrow marked on the transducer