

Closed Loop Hall Current Sensor CYHCS-D6

This Hall Effect current sensor is based on closed loop compensating principle and designed with a high galvanic isolation between primary and secondary circuits. It can be used for measurement of DC and AC current, pulse currents etc. The output of the transducer reflects the real wave of the current carrying conductor.

Product Characteristics	Applications
<ul style="list-style-type: none">• Excellent accuracy• Very good linearity• Small size and encapsulated• Less power consumption• Current overload capability	<ul style="list-style-type: none">• General Purpose Inverters• AC/DC Variable Speed Drivers• Battery Supplied Applications• Uninterruptible Power Supplies• Switched Mode Power Supplies

ELECTRICAL DATA

Part number	CYHCS-D6-300A	CYHCS-D6-500A	
Nominal current	300	500	A
Measuring range	600(±18V, 50 Ω)	1000 (±18V, 36 Ω)	A
Turns ratio	1:3000	1:5000	
Measuring resistance	with±15V DC		
	@±300A max 110(max)	@±500Amax 100(max)	Ω
	@±600A max 36(max)	@±1000Amax 25(max)	Ω
	with±18VDC		
	@±300Amax 120(max)	@±500Amax 120(max)	Ω
	@±600Amax 50(max)	@±1000Amax 36(max)	Ω
Nominal analogue output current	100±0.5%	100±0.5%	mA
Secondary internal resistance	31	45	Ω
Supply voltage	±15 ~ ±24		V
Current consumption	20 + output current		mA
Galvanic isolation	50HZ, 1min, 6		kV

ACCURACY DYNAMIC PERFORMANCE

Zero offset current	±0.2	mA
Thermal drift of offset current	-40°C ~ +85°C, ±0.5	mA
Response time	<1	µs
Linearity	≤0.1	%FS
Bandwidth(-3dB)	DC...100	kHz
di/dt following accuracy	>100	A/µs

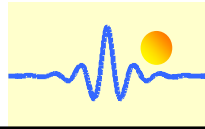

GENERAL DATA

Operating temperature	-40 ~ +85	°C
Storage temperature	-40 ~ +125	°C

Dimensions (mm)

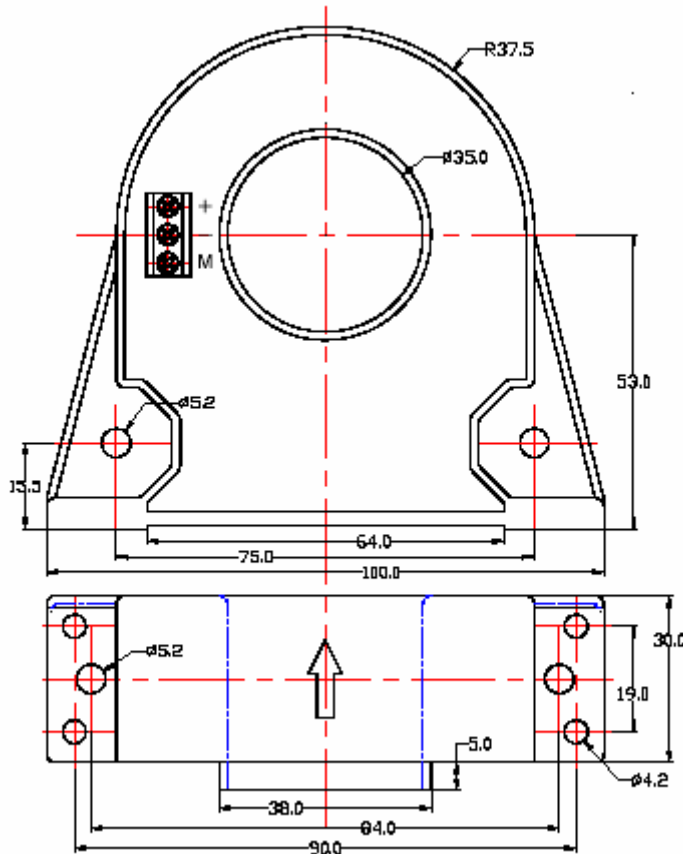

Current direction



Terminal Arrangement

+: +15V
-: -15V
M: Output

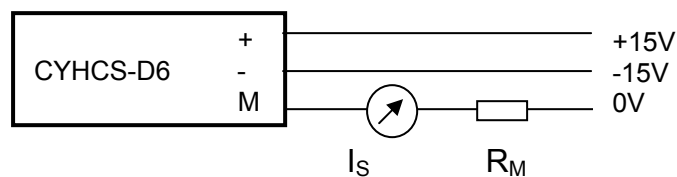

Operating instructions

1. Connect the terminals of power source, outputs respectively and correctly, never make wrong connection for DC current.
2. Temperature of the primary conductor should not exceed 120 °C.
3. Dynamic performances (di/dt and the response time) are best with a single bar completely filling the primary hole.
4. In order to achieve the best magnetic coupling, the primary windings have to be wound over the top edge of the device.