



## Open Loop Hall Current Sensor CYHCS-EA

This Hall Effect current sensor is based on open loop compensating principle and designed with a high galvanic isolation between primary and secondary circuits. It can be used for measurement of DC and AC current, pulse currents etc. The output of the transducer reflects the real wave of the current carrying conductor.

Product Characteristics	Applications
<ul style="list-style-type: none"><li>• Excellent accuracy</li><li>• Very good linearity</li><li>• Light in weight</li><li>• Less power consumption</li><li>• Window structure</li><li>• Electrically isolating the output of the transducer from the current carrying conductor</li><li>• No insertion loss</li><li>• Current overload capability</li></ul>	<ul style="list-style-type: none"><li>• <b>Photovoltaic equipment</b></li><li>• Frequency conversion timing equipments</li><li>• Various power supply</li><li>• Uninterruptible power supplies (UPS)</li><li>• Electric welding machines</li><li>• Transformer substation</li><li>• Numerical controlled machine tools</li><li>• Electric powered locomotive</li><li>• Microcomputer monitoring</li><li>• Electric power network monitoring</li></ul>

### Electrical Data

Primary Nominal RMS Current $I_r$ (A)	Measuring Range (A)	Output voltage (V)	Aperture Diameter (mm)	Part number
200	$\pm 400$	4 $\pm 1.0\%$	$\varnothing 40.5$	CYHCS-EA200A
400	$\pm 800$			CYHCS-EA400A
600	$\pm 1200$			CYHCS-EA600A
800	$\pm 1600$			CYHCS-EA800A
1000	$\pm 2000$			CYHCS-EA1000A
2000	$\pm 3000$			CYHCS-EA2000A

Supply Voltage  
Current Consumption  
Galvanic isolation, 50/60Hz, 1min:  
Load resistance:  
Isolation resistance @ 500 VDC

$V_{cc} = \pm 15V \pm 5\%$ ,  
 $I_c < 20mA$   
5kV  
10k $\Omega$   
> 500 M $\Omega$

### Accuracy and Dynamic performance data

Accuracy at  $I_r$ ,  $T_A=25^\circ C$  (without offset),  
Linearity from 0 to  $I_r$ ,  $T_A=25^\circ C$ ,  
Electric Offset Voltage,  $T_A=25^\circ C$ ,  
Magnetic Offset Voltage ( $I_r \rightarrow 0$ )  
Thermal Drift of Offset Voltage,  
Thermal Drift ( $-10^\circ C$  to  $50^\circ C$ ),  
Frequency bandwidth (-3 dB):  
Response Time at 90% of  $I_P$  ( $f=1k$  Hz)

$X < 1.0\%$   
 $E_L < 1.0\% FS$   
 $V_{oe} < 20mV$   
 $V_{om} < \pm 40mV$   
 $V_{ot} < \pm 0.5mV/^\circ C$   
T.C.  $< \pm 0.1\% /^\circ C$   
DC-50kHz  
 $t_r < 3\mu s$



## General Data

Ambient Operating Temperature,  
Ambient Storage Temperature,

$T_A = -40^{\circ}\text{C} \sim +85^{\circ}\text{C}$   
 $T_S = -55^{\circ}\text{C} \sim +125^{\circ}\text{C}$

## PIN Definition and Dimensions

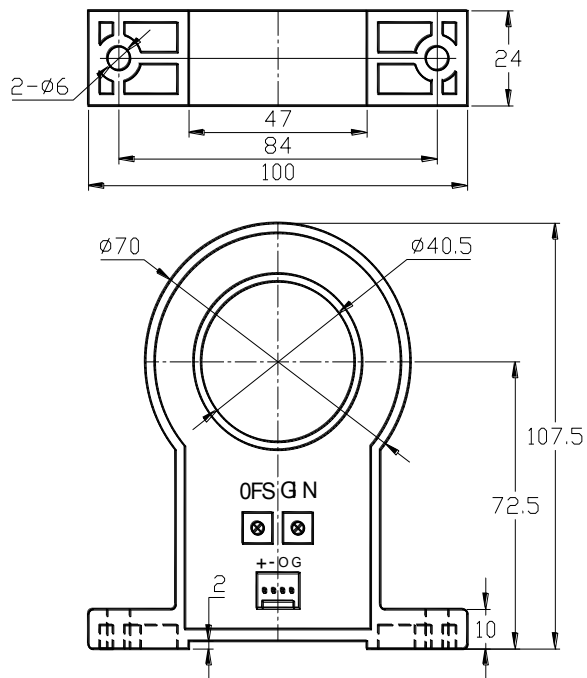

+: +15V  
-: -15V  
O: Output  
G: Ground

## Notes:

1. Connect the terminals of power source, outputs respectively and correctly, never make wrong connection.
2. Two potentiometers can be adjusted, only if necessary, by turning slowly to the required accuracy with a small screwdriver.
3. The best accuracy can be achieved when the window is fully filled with bus-bar (current carrying conductor).
4. The in-phase output can be obtained when the direction of current of current carrying conductor is the same as the direction of arrow marked on the transducer