



Split Core Hall Current Sensor CYHCS-EKAA

This Hall Effect current sensor is based on open loop compensating principle and designed with a split core and a high galvanic isolation between primary and secondary circuits. It can be used for measurement of DC and AC current, pulse currents etc. The output of the transducer reflects the real wave of the current carrying conductor.

Product Characteristics	Applications
<ul style="list-style-type: none"> • Excellent accuracy • Very good linearity • Using split cores and easy mounting • Less power consumption • Window structure • Electrically isolating the output of the transducer from the current carrying conductor • No insertion loss • Current overload capability 	<ul style="list-style-type: none"> • Photovoltaic equipment • Frequency conversion timing equipments • Various power supply • Uninterruptible power supplies (UPS) • Electric welding machines • Transformer substation • Numerical controlled machine tools • Electric powered locomotive • Microcomputer monitoring • Electric power network monitoring

Electrical Data

Primary Nominal RMS Current I_r (A)	Measuring Range (A)	Output Current (mA)	Aperture Diameter (mm)	Part number
100	± 200	0 ~20mA ±1.0%	Ø21	CYHCS-EKAA100A
200	± 400			CYHCS-EKAA200A
300	± 600			CYHCS-EKAA300A
400	± 800			CYHCS-EKAA400A
500	± 1000			CYHCS-EKAA500A

Supply Voltage
Current Consumption
Galvanic isolation, 50/60Hz, 1min:
Load resistance:
Isolation resistance @ 500 VDC

$V_{cc} = \pm 15V \pm 5\%$,
 $I_c < 20mA$
2.5kV
10kΩ
> 500 MΩ

Accuracy and Dynamic performance data

Accuracy at I_r , $T_A=25^\circ C$ (without offset),
Linearity from 0 to I_r , $T_A=25^\circ C$,
Electric Offset Voltage, $T_A=25^\circ C$,
Magnetic Offset Voltage, $T_A=25^\circ C$,
Thermal Drift of Offset Voltage,
Response Time at 90% of I_P ($f=1k$ Hz)
Frequency bandwidth (- 3 dB):

$X < 1.0\%$
 $E_L < 1.0\%$ FS
 $V_{oe} < 0.05mA$
 $V_{oe} < 0.05mA$
 $V_{ot} < \pm 0.01mA/^\circ C$
 $t_r < 5\mu s$
20Hz - 20kHz



General Data

Ambient Operating Temperature,
Ambient Storage Temperature,

$T_A = -40^{\circ}\text{C} \sim +85^{\circ}\text{C}$
 $T_S = -55^{\circ}\text{C} \sim +125^{\circ}\text{C}$

PIN Definition and Dimensions

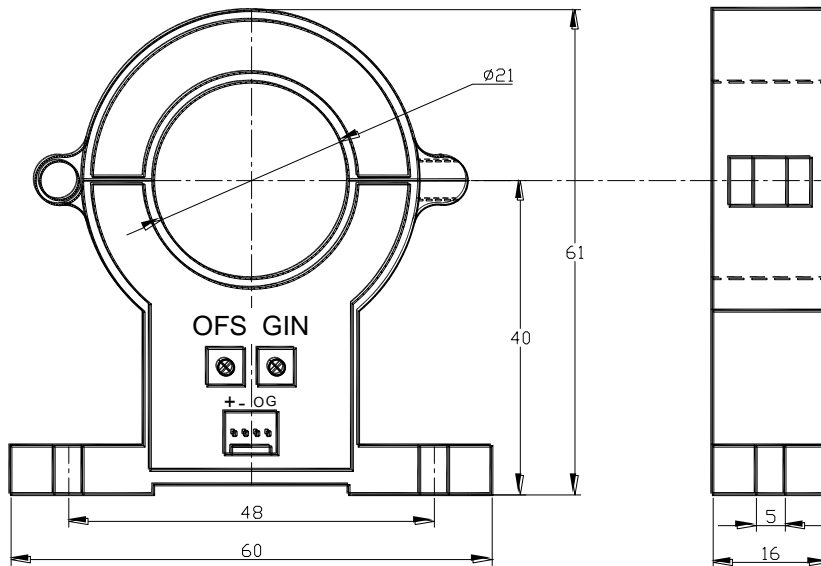

+: +15V
-: -15V
O: Output
G: Ground



Notes:

1. Connect the terminals of power source, outputs respectively and correctly, never make wrong connection.
2. Two potentiometers can be adjusted, only if necessary, by turning slowly to the required accuracy with a small screwdriver.
3. The best accuracy can be achieved when the window is fully filled with bus-bar (current carrying conductor).
4. The in-phase output can be obtained when the direction of current of current carrying conductor is the same as the direction of arrow marked on the transducer