



Split Core AC Hall Current Sensor CYHCS-EKAD

This Hall Effect current sensor is based on open loop compensating principle and designed with a split core and a high galvanic isolation between primary and secondary circuits. It can be used for measurement of AC current, pulse currents etc. The output of the transducer reflects the real wave of the current carrying conductor.

Product Characteristics	Applications
<ul style="list-style-type: none"> • Excellent accuracy • Very good linearity • Using split cores and easy mounting • Less power consumption • Window structure • Electrically isolating the output of the transducer from the current carrying conductor • No insertion loss • Current overload capability 	<ul style="list-style-type: none"> • Photovoltaic equipment • Frequency conversion timing equipments • Various power supply • Uninterruptible power supplies (UPS) • Electric welding machines • Transformer substation • Numerical controlled machine tools • Electric powered locomotive • Microcomputer monitoring • Electric power network monitoring

Electrical Data

Primary Nominal RMS Current I_r (A)	Measuring Range (A)	DC Output voltage (V)	Aperture Diameter (mm)	Part number
30	± 60	0-5 $\pm 1.0\%$	$\varnothing 21$	CYHCS-EKAD30A
50	± 100			CYHCS-EKAD50A
100	± 200			CYHCS-EKAD100A
200	± 400			CYHCS-EKAD200A
400	± 800			CYHCS-EKAD400A
500	± 1000			CYHCS-EKAD500A

Supply Voltage
Current Consumption
Galvanic isolation, 50/60Hz, 1min:
Load resistance:
Isolation resistance @ 500 VDC

$V_{cc} = \pm 15V \pm 5\%$,
 $I_c < 20mA$
2.5kV
10k Ω
> 500 M Ω

Accuracy and Dynamic performance data

Accuracy at I_r , $T_A = 25^\circ C$ (without offset),
Linearity from 0 to I_r , $T_A = 25^\circ C$,
Electric Offset Voltage, $T_A = 25^\circ C$,
Thermal Drift of Offset Voltage,
Response Time at 90% of I_P ($f = 1k$ Hz)
Frequency bandwidth (-3 dB):

$X < 1.0\%$
 $E_L < 1.0\%$ FS
 $V_{oe} < 25mV$
 $V_{ot} < \pm 0.5mV/^\circ C$
 $t_r < 20ms$
20Hz - 20kHz

General Data

Ambient Operating Temperature,
Ambient Storage Temperature,

$T_A = -40^\circ C \sim +85^\circ C$
 $T_S = -55^\circ C \sim +125^\circ C$



PIN Definition and Dimensions

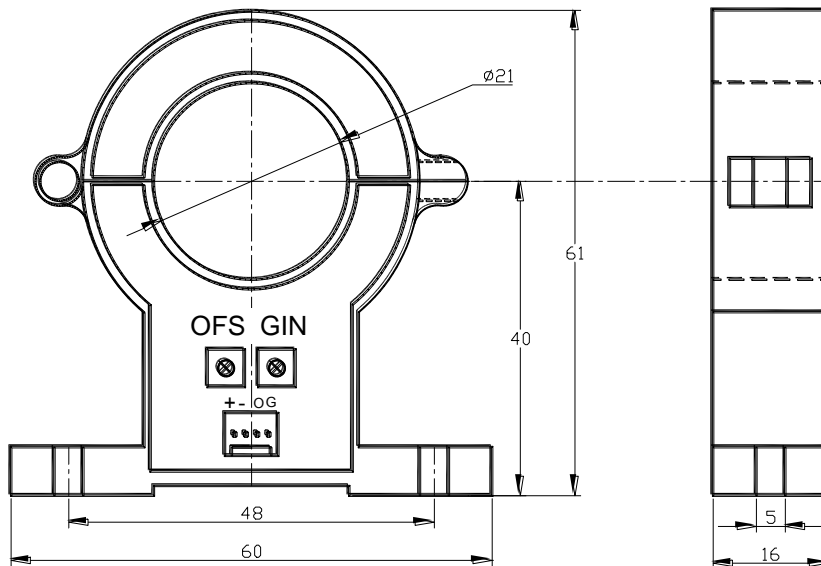

+: +15V
-: -15V
O: Output
G: Ground



Notes:

1. Connect the terminals of power source, outputs respectively and correctly, never make wrong connection.
2. Two potentiometers can be adjusted, only if necessary, by turning slowly to the required accuracy with a small screwdriver.
3. The best accuracy can be achieved when the window is fully filled with bus-bar (current carrying conductor).
4. The in-phase output can be obtained when the direction of current of current carrying conductor is the same as the direction of arrow marked on the transducer