

Closed Loop Hall Current Sensor CYHCS-P

This Hall Effect current sensor is based on the closed loop compensating principle and designed with a high galvanic isolation between primary and secondary circuits. It can be used for measurement of DC and AC current, pulse currents etc. The output of the transducer reflects the real wave of the current carrying conductor.

Product Characteristics	Applications
<ul style="list-style-type: none">• Excellent accuracy• Very good linearity• Small size and encapsulated• Less power consumption• Current overload capability	<ul style="list-style-type: none">• General Purpose Inverters• AC/DC Variable Speed Drivers• Battery Supplied Applications• Uninterruptible Power Supplies• Switched Mode Power Supplies

Electrical Data/Input

Part number	Primary Rated Current I_r (A)	Measuring Range I_p (A)	Primary Conductor (mm)	Turns ratio	Internal measuring resistor (Ω)
CYHCS-P03A	3	± 9	$\varnothing 0.6$	7:2100	400
CYHCS-P05A	5	± 15	$\varnothing 0.8$	4:2000	400
CYHCS-P10A	10	± 30	$\varnothing 0.8$	3:3000	400
CYHCS-P15A	15	± 45	$\varnothing 1.0$	2:3000	400
CYHCS-P20A	20	± 60	$\varnothing 1.4$	2:2000	400
CYHCS-P25A	25	± 75	$\varnothing 1.4$	1:2500	400
CYHCS-P30A	30	± 90	$\varnothing 1.6$	1:3000	400
CYHCS-P50A	50	± 150	$\varnothing 2.0$	1:3125	250

Rated Output Voltage:	$\pm 4V \pm 0.5\%$
Supply Voltage	$\pm 15V \pm 5\%$,
Current Consumption (at $V_{out}=0V$)	12mA
Isolation voltage (50/60Hz, 1min)	3.5kV
Accuracy:	0.5%
Linearity:	<0.1% FS
Electric Offset Voltage	$\pm 20mV$
Thermal Drift of Offset Voltage,	$\pm 0.5mV/^\circ C$
Response Time:	< 1 μs
Frequency Bandwidth:	DC ~ 150kHz

General Data

Ambient Operating Temperature:	-40°C ~ +85°C
Ambient Storage Temperature:	-40°C ~ +125°C

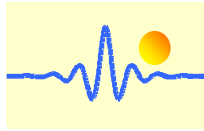

PIN Definition

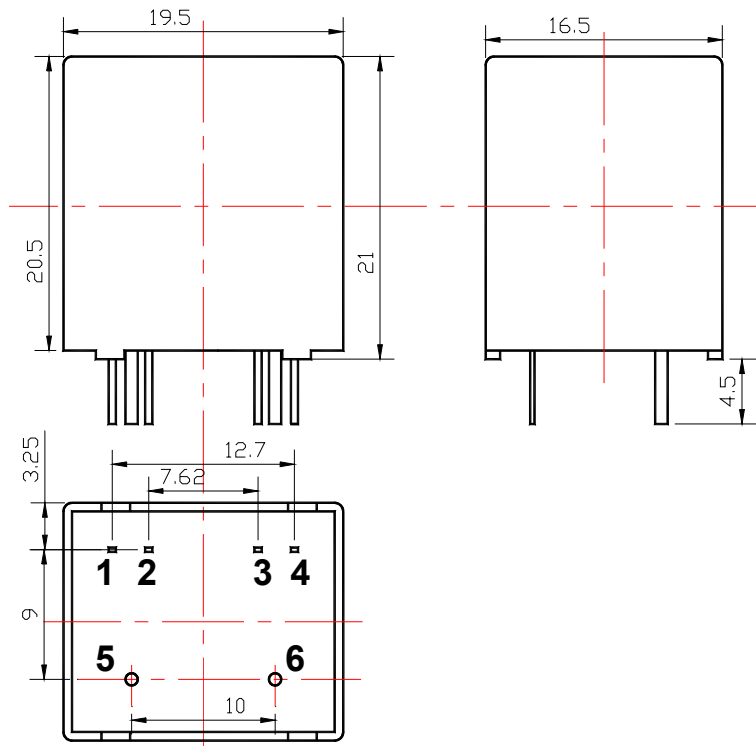

Terminal Pin Identification

- 1.....OUTPUT
- 2.....+15V
- 3.....-15V
- 4.....0V
- 5.....primary input current(--)
- 6.....primary input current(+)

Operating instructions

1. Connect the pins of power source, outputs respectively and correctly, never make wrong connection for DC current.
2. Temperature of the primary conductor should not exceed 100 °C.

Custom Sensors with other input current and output voltage are available