



## Hall Effect AC/DC Current Sensor CYHCS-WS3

The sensor CYHCS-WS3 is a Hall Effect sensor for the measurement of AC/DC current. The sensor has a galvanic isolation between the high power primary and the secondary electronic circuits with voltage output.

Features and Advantages	Applications
<ul style="list-style-type: none"> <li>AC/DC current measurement</li> <li>Output signal option (0-20mA, 4-20mA, 0-5V, <math>\pm 5V</math>, 0-10V)</li> <li>35mm DIN Rail</li> <li>High isolation between primary and secondary circuits</li> <li>No insertion losses</li> <li>Split Core, easy installation</li> </ul>	<ul style="list-style-type: none"> <li><b>Photovoltaic equipment</b></li> <li>Battery banks, such as, monitoring load current and charge current, verifying operation</li> <li>Transportation, measuring traction power or auxiliary loads</li> <li>Phase fired controlled heaters</li> <li>Directly connect to PLC</li> <li>Sense motor stalls and short circuits</li> </ul>

### Specifications

Rated input current	20A, 30A, 50A, 80A, 100A, 150A, 200A, 300A
Linear measuring range	1.2 times of rated input current
Output signals	$\pm 5V$ AC/DC, 0-5VDC, 0-10VDC, 0-20mADC, 4-20mADC
Power supply	+12V DC, +15VDC, +24V DC
Measuring accuracy	$\pm 1.0\%$
Linearity (10% - 100%), 25°C	$\leq \pm 0.5\%$
Zero offset voltage	$\pm 25mV$
Hysteresis error	$\pm 10mV$
Thermal drift of offset voltage	$\leq 400PPM/^\circ C$
Galvanic isolation	6 kV AC, 50Hz, 1min
Isolation resistance	$\geq 100M\Omega$
Response time	$\leq 3\mu s$ for tracing output, $\leq 100ms$ DC output
Frequency range	DC ~ 10kHz
di/dt following accuracy	50A/ $\mu s$
Overload capacity	20 times
Current consumption	$\leq 50mA$
Output load	Voltage output : $\geq 2k\Omega$ , Current output: $\leq 250\Omega$
Mounting	35mm DIN Rail
Case style and Window size	WS3 with aperture $\varnothing 20mm$
Protection of Case	IP20
Operating temperature	$-25^\circ C \sim +70^\circ C$
Storage temperature	$-45^\circ C \sim +85^\circ C$
Relative humidity	$\leq 90\%$
Mean Time Between Failures (MTBF)	$\geq 100k$ hours

### Definition of Part number:

CYHCS	-	WS3	-	m	-	x	n
-------	---	-----	---	---	---	---	---

(1)                      (2)                      (3)                      (4) (5)



(1)	(2)	(3)	(4)	(5)
Series name	Case style	Rated Input current (m)	Output signal	Power supply
CYHCS	WS3	m = 20A, 30A, 50A, 80A, 100A, 150A, 200A, 250A, 300A	<b>x=1:</b> tracing voltage $\pm 5V$ AC/DC <b>x=3:</b> 0-5V DC <b>x=4:</b> 0-20mA DC <b>x=5:</b> 4-20mA DC <b>x=8:</b> 0-10V DC	<b>n=2:</b> +12V DC <b>n=3:</b> +15V DC <b>n=4:</b> +24V DC

**Example 1:** CYHCS-WS3-100A -34, Hall Effect DC Current sensor with  
 Output signal: 0-5V DC  
 Power supply: +24V DC  
 Rated input current: 100A DC

**Example 2:** CYHCS-WS3-100A -54, Hall Effect DC Current sensor with  
 Output signal: 4-20mA DC  
 Power supply: +24V DC  
 Rated input current: 100A DC

### DIMENSIONS (mm)

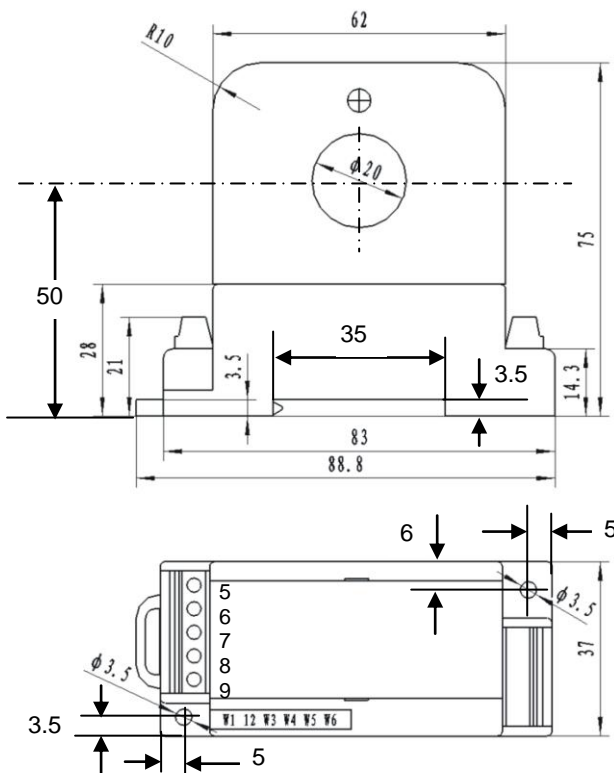

Dimensions: 75mm x 83mm x 37mm, Aperture:  $\varnothing 20$  mm



### CONNECTIONS

The current carrying cable must pass through the window. The phase of output is the same as that of the current passing the window in the direction of the arrow indicated on the case.



**Wiring of Terminals for voltage output:**

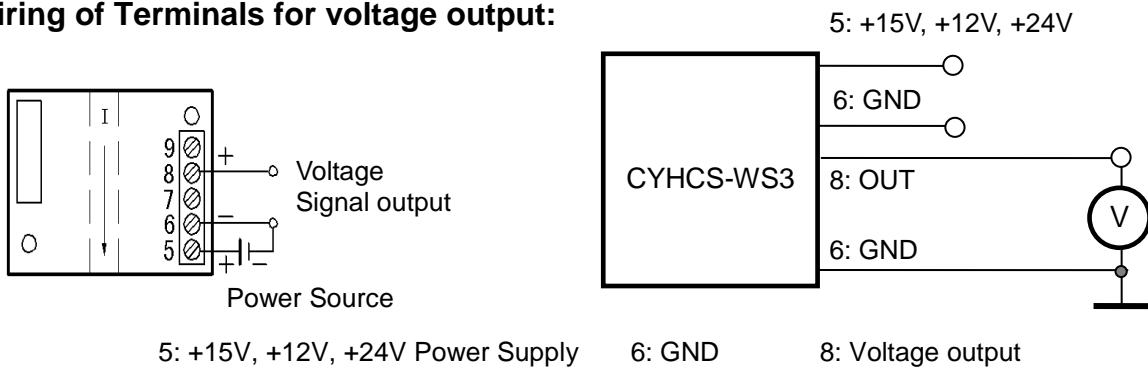

**Relation between Input and Output:**

Sensor CYHCS-WS3-100A-34	
Input current (A)	Output voltage (V)
0	0
25	1.25
50	2.5
75	3.75
100	5

**Wiring of Terminals for Current Output:**

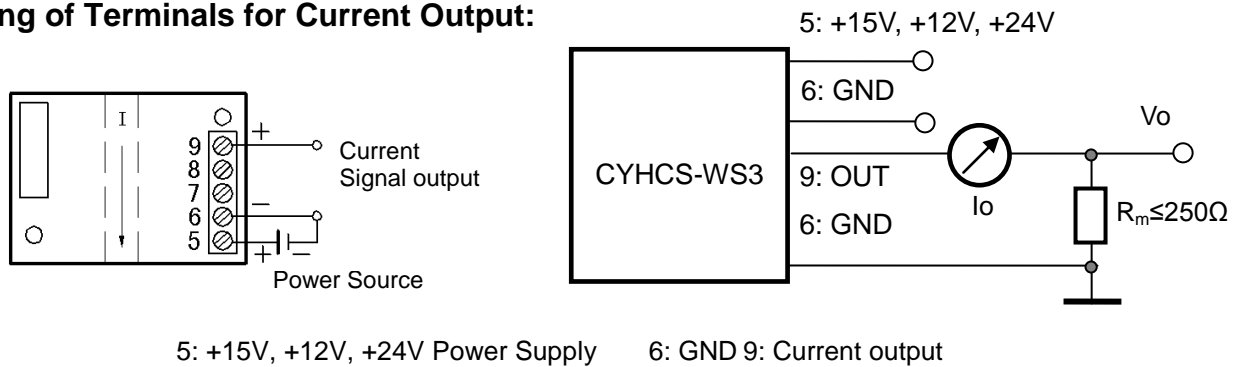

**Relation between Input and Output (for  $R_m=250 \Omega$ ):**

Sensor CYHCS-WS3-100A-54		
Input current (A)	Output current $I_o$ (mA)	Output voltage $V_o$ (V)
0	4	1
25	8	2
50	12	3
75	16	4
100	20	5

**Notes:**

1. Connect the terminals of power source, outputs respectively and correctly, never make wrong connection.
2. Two potentiometers can be adjusted, only if necessary, by turning slowly to the required accuracy with a small screw driver.
3. The best accuracy can be achieved when the window is fully filled with bus-bar (current carrying conductor).
4. The in-phase output can be obtained when the direction of current of current carrying conductor is the same as the direction of arrow marked on the transducer case.