

Hall Current Sensor CYHCS013-C

Electrical Data/Input

Primary Nominal RMS Current I_r (A)	Primary Current Measuring Range I_p (A) at $V_{cc}=15V$	Primary Conductor Φ (mm)	Part Number
3	± 6	0.6	CYHCS-M0030-C
5	± 10	0.8	CYHCS-M0050-C
10	± 20	1.0	CYHCS-M0100-C
15	± 30	1.6	CYHCS-M0150-C
20	± 40	1.6	CYHCS-M0200-C
25	± 50	1.6	CYHCS-M0250-C
30	± 60	1.6	CYHCS-M0300-C
35	± 70	1.6x2	CYHCS-M0350-C
40	± 80	1.6x2	CYHCS-M0400-C
45	± 90	1.6x2	CYHCS-M0450-C
50	± 100	1.6x2	CYHCS-M0500-C

Supply Voltage
Current Consumption
RMS Voltage for 2.5kV AC isolation test, 50/60Hz, 1min,
Isolation Resistance at 500V DC

$V_{cc} = 15V \pm 5\%$,
 $I_c < 20mA$
 $V_{is} < 10mA$
 $R_{is} > 500 M\Omega$

Electrical Data/Output

Output Voltage at I_r , $T_A=25^\circ C$:
Output Impedance:
Load Resistor:

$V_{out} = V_{EO} \pm 2V$
 $R_{out} < 150\Omega$
 $R_L > 10k\Omega$

Accuracy

Accuracy at I_r , $T_A=25^\circ C$ (without offset),
Linearity from 0 to I_r , $T_A=25^\circ C$,
Electric Offset Voltage, $T_A=25^\circ C$,
Hysteresis Offset Voltage ($I_r \rightarrow 0$)
Thermal Drift of Offset Voltage,
Thermal Drift ($-C0^\circ C$ to $50^\circ C$),
Response Time at 90% of I_P ($f=1kHz$)
Frequency Bandwidth (-3dB),

$X < 1.0\%$
 $E_L < 1.0\%$
 $V_{EO} = 5.0V \pm 50mV$
 $V_{om} < 20mV$
 $V_{ot} < 2mV/^\circ C$
T.C. $< \pm 0.1\% / ^\circ C$
 $t_r < 3\mu s$
 $f_b = 50 kHz$

General Data

Ambient Operating Temperature,
Ambient Storage Temperature,

$T_A = -10^\circ C \sim +80^\circ C$
 $T_S = -25^\circ C \sim +85^\circ C$

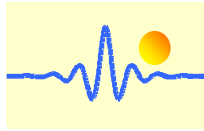

Functional Block Diagram

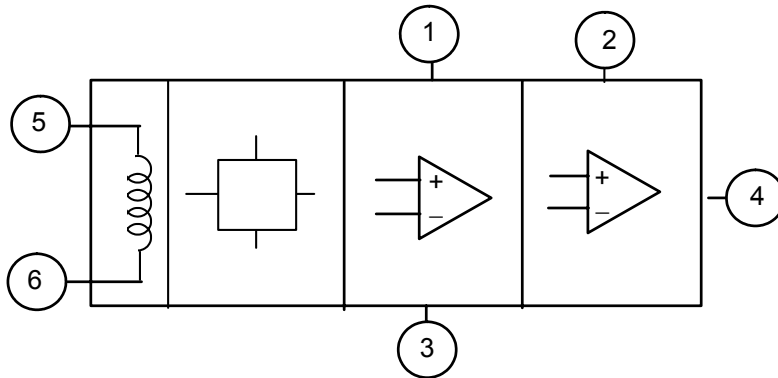

1. Ground or floating
2. Ground
3. V+
4. V_{output}
5. Coil Input +
6. Coil Input -

PIN Definition

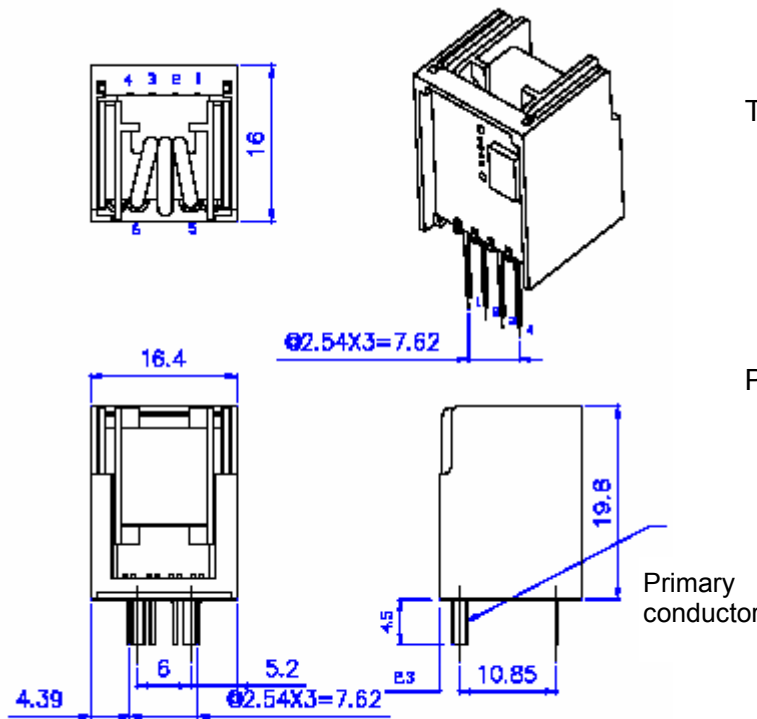

Terminal PIN Definition

1. Ground/floating
2. Ground
3. V+
4. Output
5. Coil Input +
6. Coil Input -

Primary Conductor Terminal

- CYHCS-M0030-C ϕ 0.6
- CYHCS-M0050-C ϕ 0.8
- CYHCS-M0100-C ϕ 1.0
- CYHCS-M0150-C ϕ 1.6
- CYHCS-M0200-C ϕ 1.6
- CYHCS-M0250-C ϕ 1.6
- CYHCS-M0300-C ϕ 1.6
- CYHCS-M0350-C ϕ 1.6x2
- CYHCS-M0400-C ϕ 1.6x2
- CYHCS-M0450-C ϕ 1.6x2
- CYHCS-M0500-C ϕ 1.6x2

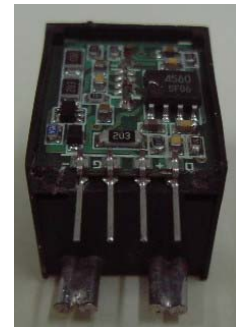
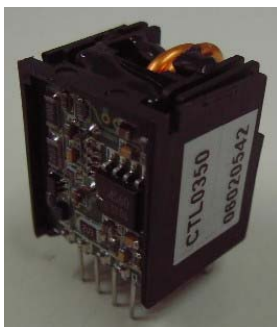

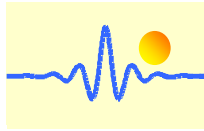

Hole Recommend

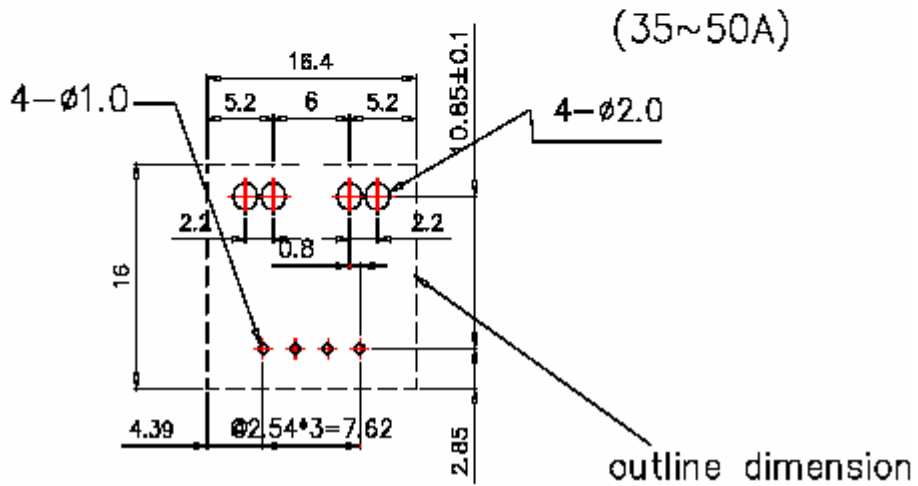
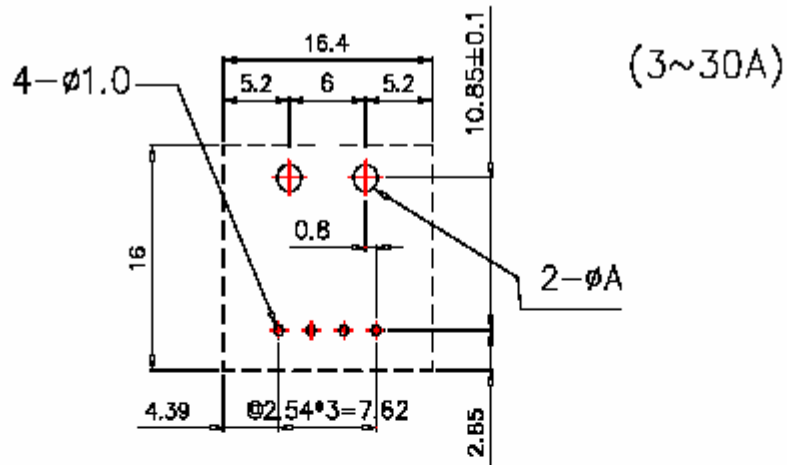

Part Name	ΦA(mm)
CYHCS-M0030-C	1.0
CYHCS-M0050-C	1.2
CYHCS-M0100-C	1.4
CYHCS-M0150-C	2.0
CYHCS-M0200-C	2.0
CYHCS-M0250-C	2.0
CYHCS-M0300-C	2.0

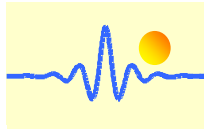

Relation between Input Current and Output Voltage

Take the sensor CYHCS-M0100-C as sample, the relation between the input current and output voltage is shown in the table 1, Fig.1 and Fig. 2

Table 1. Relation between the input current and output voltage

Input current (A)	-20	-15	-10	-5	0	5	10	15	20
Output voltage (V)	1.0	2.0	3.0	4.0	5.0	6.0	7.0	8.0	9.0

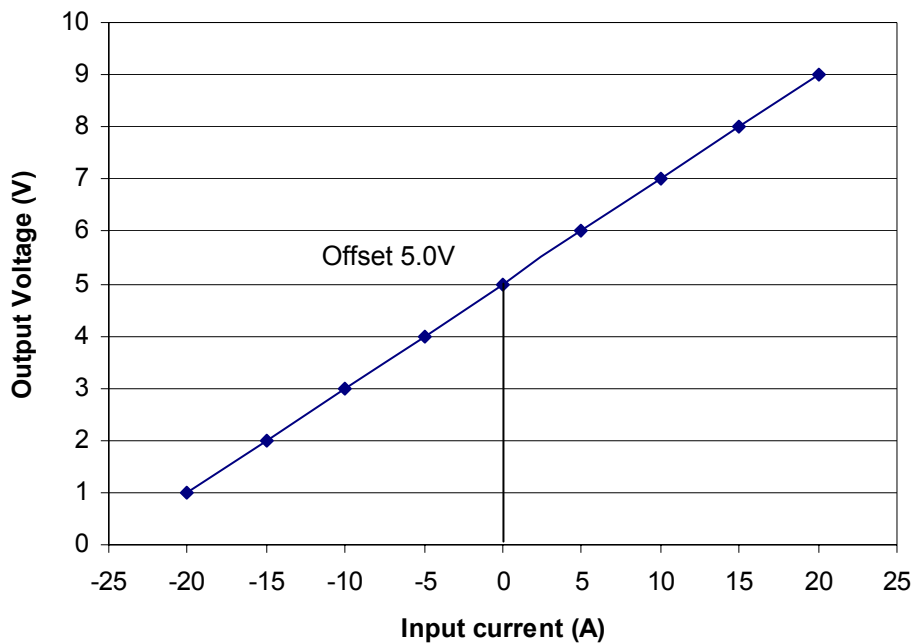

Fig. 1 Relation between the input current (DC) and output voltage (DC)

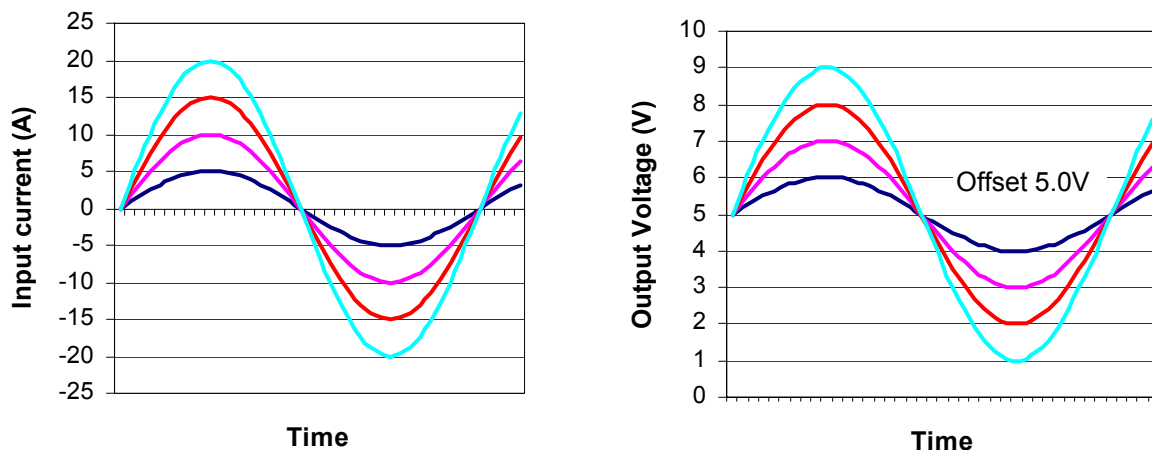

Fig. 2 Relation between the input current (AC) and output voltage (AC)