

## Split Core Hall Effect DC Current Sensor CYHCT-C2TC

This Hall Effect current sensor is based on open loop principle and designed with a split core and a high galvanic isolation between primary conductor and secondary circuit. It can be used for measurement of DC current etc. The output of the transducer reflects the real wave of the current carrying conductor.

Product Characteristics	Applications
<ul style="list-style-type: none"> <li>• Excellent accuracy</li> <li>• Very good linearity</li> <li>• Using split cores and easy mounting</li> <li>• Less power consumption</li> <li>• Window structure</li> <li>• Electrically isolating the output of the transducer from the current carrying conductor</li> <li>• No insertion loss</li> <li>• Current overload capability</li> </ul>	<ul style="list-style-type: none"> <li>• <b>Photovoltaic equipment</b></li> <li>• Frequency conversion timing equipment</li> <li>• Various power supply</li> <li>• Uninterruptible power supplies (UPS)</li> <li>• Electric welding machines</li> <li>• Transformer substation</li> <li>• Numerical controlled machine tools</li> <li>• Electric powered locomotive</li> <li>• Microcomputer monitoring</li> <li>• Electric power network monitoring</li> </ul>

### Electrical Data

Primary Nominal DC Current $I_r$ (A)	Measuring Range (A)	DC Output Current (mA)	Part number
25	0 ~ ±25A	4-20 ±1.0%	CYHCT-C2TC-U/B25A-nC
30	0 ~ ±30A		CYHCT-C2TC-U/B30A-nC
40	0 ~ ±40A		CYHCT-C2TC-U/B40A-nC
50	0 ~ ±50A		CYHCT-C2TC-U/B50A-nC
100	0 ~ ±100A		CYHCT-C2TC-U/B100A-nC
200	0 ~ ±200A		CYHCT-C2TC-U/B200A-nC
300	0 ~ ±300A		CYHCT-C2TC-U/B300A-nC
400	0 ~ ±400A		CYHCT-C2TC-U/B400A-nC
500	0 ~ ±500A		CYHCT-C2TC-U/B500A-nC
600	0 ~ ±600A		CYHCT-C2TC-U/B600A-nC

(U: unidirectional input current; B: bidirectional input current, please give U or B in Part number)  
(n=3,  $V_{cc}=+12VDC \pm 5\%$ ; n=4,  $V_{cc}=+15VDC \pm 5\%$ ; n=5,  $V_{cc}=+24VDC \pm 5\%$ )  
(Connector: Molex connector C=M; Phoenix Connector: C=P)

Supply Voltage

$V_{cc}=+12V, +15V, +24VDC \pm 5\%$

Current Consumption

$I_c < 25mA + \text{Output current}$

Galvanic isolation, 50/60Hz, 1min:

2.5kV

Isolation resistance @ 500 VDC

> 500 MΩ

### Accuracy and Dynamic performance data

Accuracy at  $I_r, T_A=25^\circ C$ ,  
Linearity from 0 to  $I_r, T_A=25^\circ C$ ,  
Electric Offset Current,  $T_A=25^\circ C$ ,  
Thermal Drift of Offset current,  
Response Time at 90% of  $I_P$   
Load resistance:  
Frequency Bandwidth (-3dB),  
Case Material:

<1.0% FS  
 $E_L < 1.0\% \text{ FS}$   
4mA DC or 12mA DC  
<±0.005mA/°C  
 $t_r < 10\mu s$   
80-450Ω  
 $f_b = \text{DC} - 20 \text{ kHz}$   
PBT

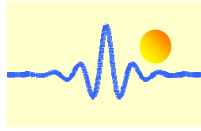

## General Data

Ambient Operating Temperature,  
Ambient Storage Temperature,

$T_A = -25^{\circ}\text{C} \sim +85^{\circ}\text{C}$   
 $T_S = -40^{\circ}\text{C} \sim +100^{\circ}\text{C}$

## PIN Definition and Dimensions

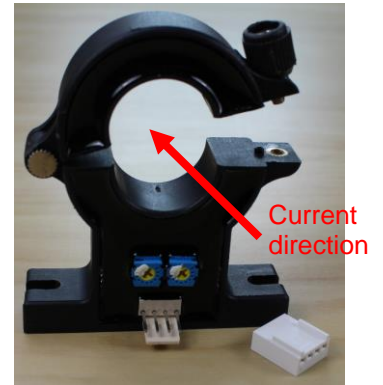
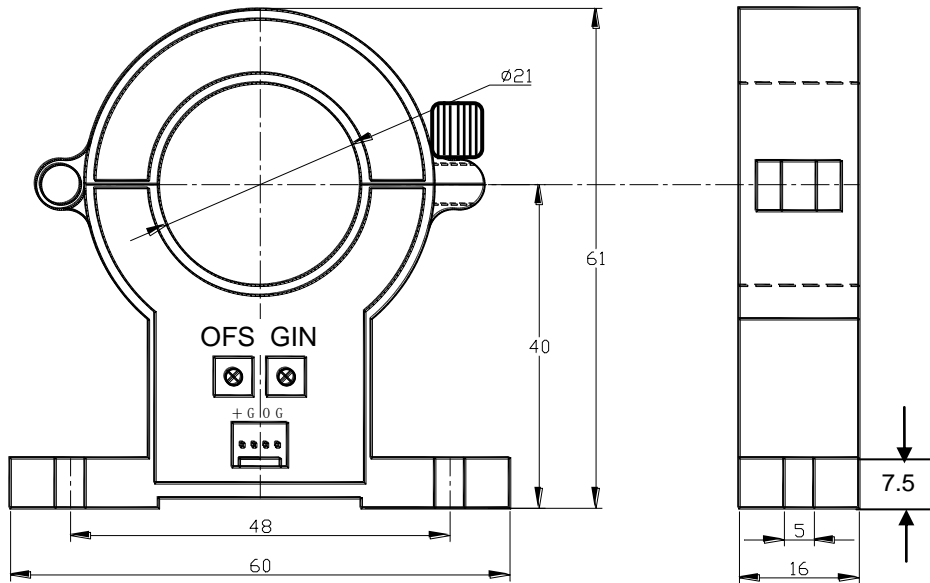

1(+): Vcc  
2(G): GND  
3(O): Output  
4(G): GND

OFS: Offset Adjustment

GIN: Gain Adjustment

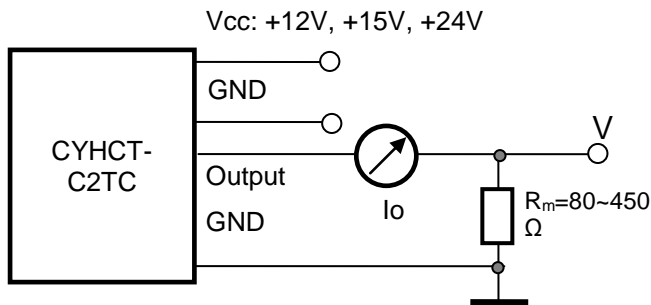

## Notes:

1. Connect the terminals of power source, output respectively and correctly, never make wrong connection.
2. Two potentiometers can be adjusted, only if necessary, by turning slowly to the required accuracy with a small screwdriver.
3. The best accuracy can be achieved when the window is fully filled with bus-bar (current carrying conductor).
4. The in-phase output can be obtained when the direction of current of current carrying conductor is the same as the direction of arrow marked on the transducer

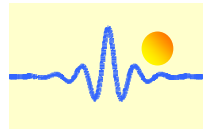

## DIN Rail Adapter CY-DRA88

The DIN Rail Adapter CY-DRA88 is designed for mounting the sensor on 35mm DIN Rail. It has the size 70 x 24 x 23mm. The height from bottom to mounting surface is 14.8mm.

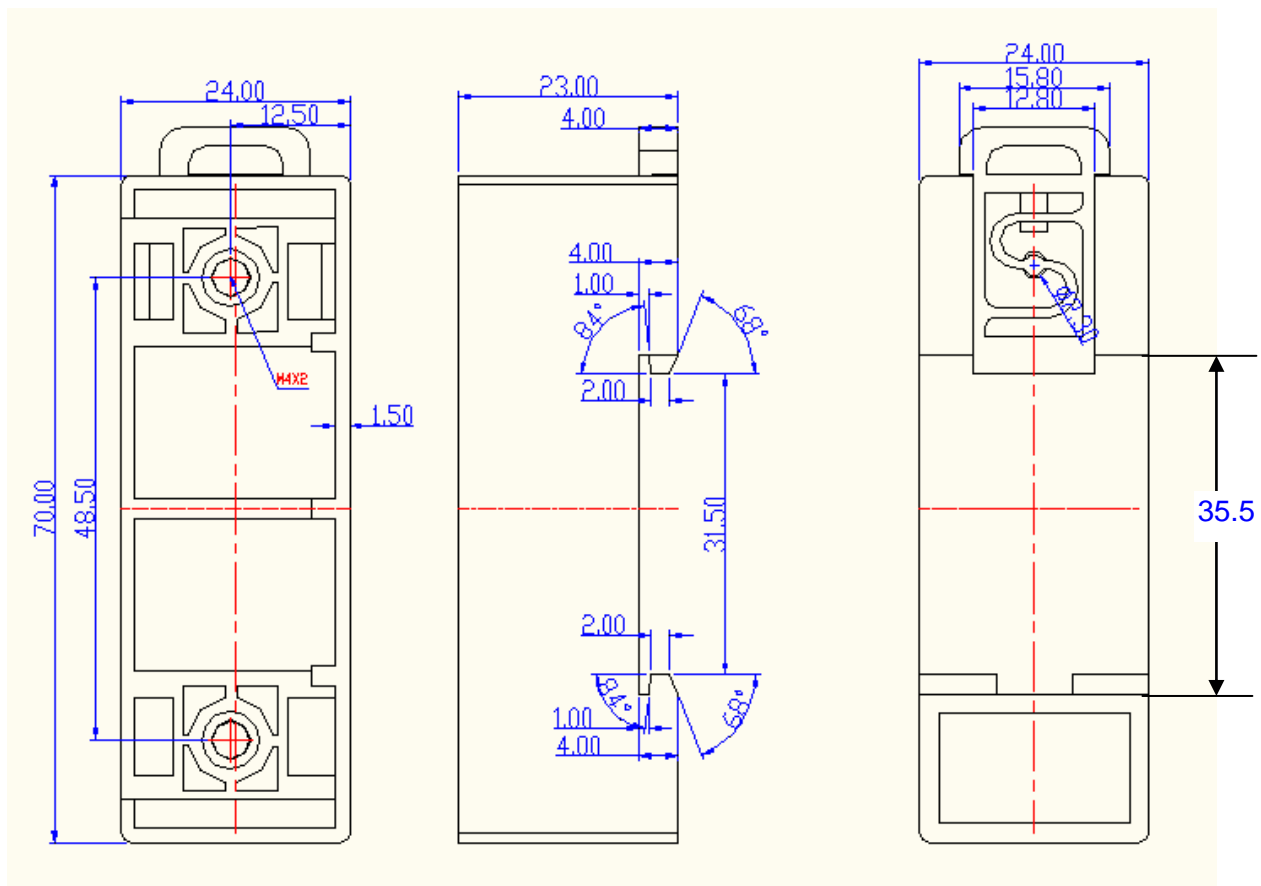
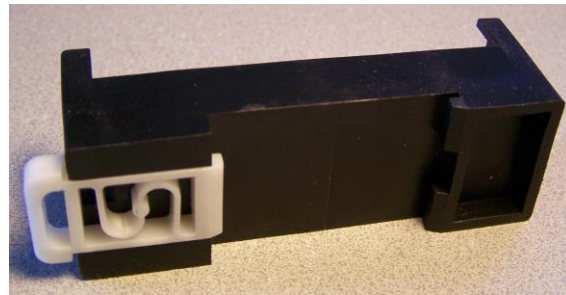

## Mounting of Sensors



Sensor with Molex Connector  
(The distance between the bottom und the middle of hole is 54.8mm)



Sensor with Phoenix Connector  
(The distance between the bottom und the middle of hole is 54.8mm)