



Hall Effect DC Current Sensor CYHCT-E5

This Hall Effect current sensor is based on open loop principle and can be used for measurement of DC currents.

Product Characteristics	Applications
<ul style="list-style-type: none">• Excellent accuracy• Very good linearity• Small size• Light in weight• Less power consumption• Window structure• Electrically isolating the output of the transducer from the current carrying conductor• No insertion loss• Current overload capability	<ul style="list-style-type: none">• Photovoltaic equipment• Frequency conversion timing equipments• Various power supply• Uninterruptible power supplies (UPS)• Electric welding machines• Transformer substation• Numerical controlled machine tools• Electrolyzing and electroplating equipments• Electric powered locomotive• Microcomputer monitoring• Electric power network monitoring

Electrical Data

Measuring range M	200A	300A	400A	500A	600A	700A	800A
Linearity range	400A	510A	600A	650A	720A	840A	900A
Overload capacity	20 x M (measuring range)						
Nominal output signals	0-4V, 0-5V, 0-10V, -5V~+5V, 0-20mA, 4-20mA, -20mA~+20mA,						
Supply voltage	+12VDC, +15VDC, +24VDC, ±12VDC, ±15VDC						
Current consumption	25mA ~ 50mA + output current						
Galvanic isolation	3KV RMS/50Hz/min						

Accuracy and Dynamic Performances

Zero offset voltage	±20	mV
Hysteresis error	±10	mV
Thermal drift of offset current	≤250	ppm/°C
Response time	≤15 (di/dt=50A/μs)	μs
Accuracy	±1.0	%
Linearity	≤1.0	%FS

General Data

Operating temperature	-10 ~ +80	°C
Storage temperature	-25 ~ +85	°C



Definition of Part number:

CYHCT	-	E5	-	M	-	x	n
(1)		(2)		(3)		(4)	(5)

(1)	(2)	(3)	(4)	(5)
Series name	Case style	Rated Input current (M=U/B + m)	Output signal	Power supply
CYHCT	E5	m = 200A, 300A, 400A, 500A, 600A, 700A, 800A	x=0: 0-4V DC x=3: 0-5V DC x=4: 0-20mA DC x=5: 4-20mA DC x=8: 0-10V DC	n=2: +12V DC n=3: +15V DC n=4: +24V DC n=5: ±12V DC n=6: ±15V DC

U: unipolar input current; **B:** bipolar input current

Output Signal of Custom Made Sensors:

x=1: tracing voltage 5V, **x=2:** tracing current 20mA

Example 1: CYHCT-E5-U500A -34, Hall Effect DC Current sensor with
 Output signal: 0-5V DC
 Power supply: +24V DC
 Rated input current: 0-500A DC (unipolar)

Example 2: CYHCT-E5-B500A -34, Hall Effect DC Current sensor with
 Output signal: 0-5V DC
 Power supply: +24V DC
 Rated input current: -500A ~ +500ADC (bipolar)

DIMENSIONS (mm)

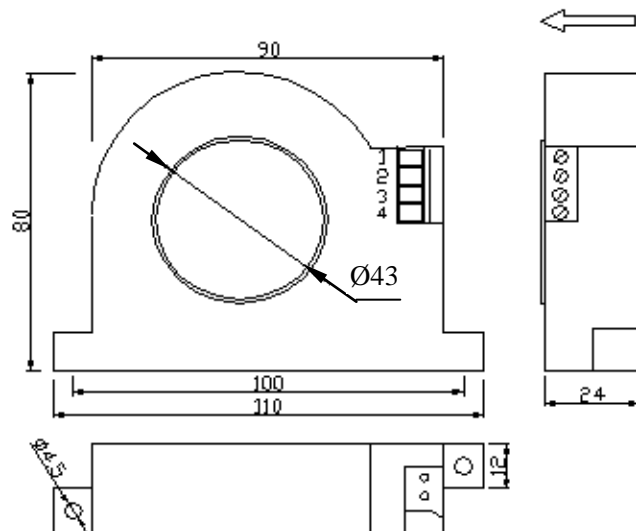
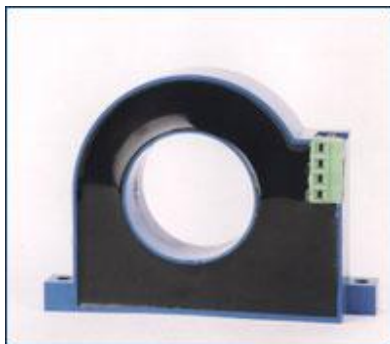



CONNECTION

The current carrying cable must pass through the window. The phase of output is the same as that of the current passing the window in the direction of the arrow indicated on the case.

a) Wiring of Sensors Using Double Power Supplies

Voltage Output

- 1(+): +15V/+12V Power Supply
- 2(-): -15V/-12V Power Supply
- 3(M): Output
- 4(G): Ground

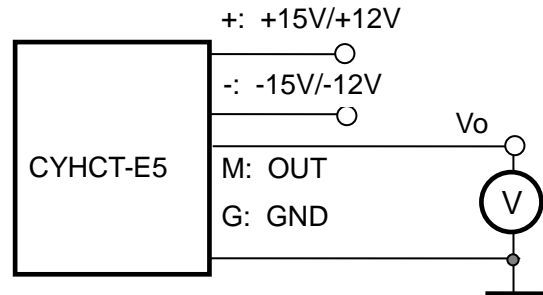

Relation between Input and Output:

Sensor CYHCT-E5-U500A -35		Sensor CYHCT-E5-B500A -35	
Input current (A)	Output voltage (V)	Input current (A)	Output voltage (V)
0	0	-500	0
125	1.25	-250	1.25
250	2.5	0	2.5
375	3.75	250	3.75
500	5	500	5

Current Output

- 1(+): +15V/+12V Power Supply
- 2(-): -15V/-12V Power Supply
- 3(M): Output
- 4(G): Ground

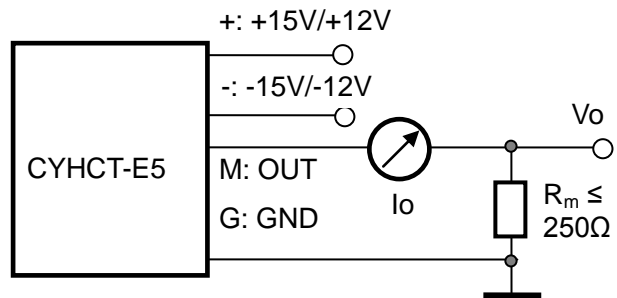

Relation between Input and Output (for $R_m=250 \Omega$):

Sensor CYHCT-E5-U500A -45			Sensor CYHCT-E5-B500A -45		
Input current (A)	Output current I_o (mA)	Output voltage V_o (V)	Input current (A)	Output current I_o (mA)	Output voltage V_o (V)
0	0	0	-500	0	0
125	5	1.25	-250	5	1.25
250	10	2.5	0	10	2.5
375	15	3.75	250	15	3.75
500	20	5	500	20	5



B) Wiring of Sensors Using Single Power Supply

Voltage Output

1(+): +15V, +12V, +24V
 2(-): NC
 3(M): Output
 4(G): Ground

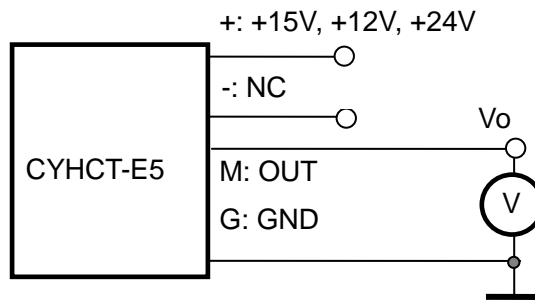

Relation between Input and Output:

Sensor CYHCT-E5-U500A -34		Sensor CYHCT-E5-B500A -34	
Input current (A)	Output voltage (V)	Input current (A)	Output voltage (V)
0	0	-500	0
125	1.25	-250	1.25
250	2.5	0	2.5
375	3.75	250	3.75
500	5	500	5

Current Output

1(+): +15V, +12V, +24V
 2(-): NC
 3(M): Output
 4(G): Ground

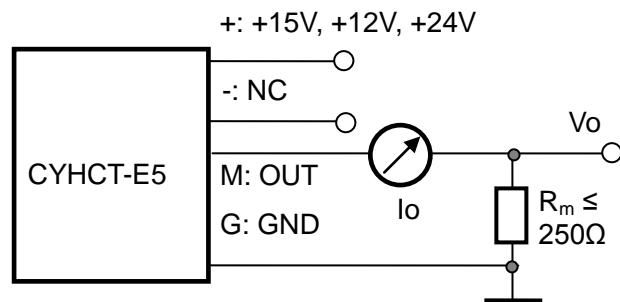

Relation between Input and Output (for $R_m=250 \Omega$):

Sensor CYHCT-E5-U500A -54			Sensor CYHCT-E5-B500A -54		
Input current (A)	Output current I_o (mA)	Output voltage V_o (V)	Input current (A)	Output current I_o (mA)	Output voltage V_o (V)
0	4	1	-500	4	1
125	8	2	-250	8	2
250	12	3	0	12	3
375	16	4	250	16	4
500	20	5	500	20	5

Notes:

1. Connect the terminals of power source, outputs respectively and correctly, never make wrong connection.
2. Two potentiometers can be adjusted, only if necessary, by turning slowly to the required accuracy with a small screwdriver.
3. The best accuracy can be achieved when the window is fully filled with bus-bar (current carrying conductor).
4. The in-phase output can be obtained when the direction of current of current carrying conductor is the same as the direction of arrow marked on the transducer case.