

Hall Effect DC Current Sensor CYHCT-KCC

This Hall Effect current sensor is based on open loop principle and designed with a split core and a high galvanic isolation between primary conductor and secondary circuit. It can be used for measurement of DC current etc. The output of the transducer reflects the real wave of the current carrying conductor.

Product Characteristics	Applications
<ul style="list-style-type: none"> • Excellent accuracy • Very good linearity • Less power consumption • Window structure with split core • Electrically isolating the output of the transducer from the current carrying conductor • No insertion loss • Current overload capability 	<ul style="list-style-type: none"> • Photovoltaic equipment • Frequency conversion timing equipment • Various power supply • Uninterruptible power supplies (UPS) • Electric welding machines • Numerical controlled machine tools • Electrolyzing and electroplating equipment • Electric powered locomotive • Microcomputer monitoring • Electric power network monitoring

Electrical Data/Input

Primary Nominal DC Current I_r (A)	Primary Current Measuring Range I_p (A)	Output current (mA)	Part number
1000A	0 ~ ± 1000A	4-20mA	CYHCT-KCC-U/B1000A-n
2000A	0 ~ ± 2000A		CYHCT-KCC-U/B2000A-n
3000A	0 ~ ± 3000A		CYHCT-KCC-U/B3000A-n
4000A	0 ~ ± 4000A		CYHCT-KCC-U/B4000A-n
5000A	0 ~ ± 5000A		CYHCT-KCC-U/B5000A-n
6000A	0 ~ ± 6000A		CYHCT-KCC-U/B6000A-n
8000A	0 ~ ± 8000A		CYHCT-KCC-U/B8000A-n
10000A	0 ~ ± 10000A		CYHCT-KCC-U/B10000A-n

(n=2, V_{cc} = +12VDC; n=3, V_{cc} =+15VDC; n=4, V_{cc} =+24VDC, n=5, V_{cc} =±12VDC, n=6, V_{cc} =±15VDC, n=7, V_{cc} =±24VDC, U: unidirectional, B: bidirectional)

Supply Voltage:

Current Consumption

Isolation Voltage

V_{cc} =+12V, +15V, +24V± 5%

I_c < 50mA + Output current

6kV, 50/60Hz, 1min

Accuracy and Dynamic performance data

Accuracy at I_r , T_A =25°C (without offset),

Linearity from 0 to I_r , T_A =25°C,

Electric Offset Current, T_A =25°C,

Thermal Drift of Offset current,

Load resistance:

Response Time at 90% of I_p (f =1k Hz)

Frequency Bandwidth (-3dB),

<1.0%

E_L <1.0% FS

4mA DC or 12mA DC

<±0.005mA/°C

80-450Ω

t_r < 1ms

f_b = DC-3 kHz

General Data

Ambient Operating Temperature,

Ambient Storage Temperature,

T_A =-25°C ~ +85°C

T_S =-40°C ~ +100°C

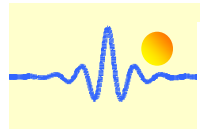

PIN Definition and Dimensions

OFS: Offset Adjustment

GIN: Gain Adjustment

Pin arrangement:

- 1(V+): Vcc
- 2(V-): -Vcc or GND
- 3(OUT): OUTPUT
- 4(GND): 0V (GND)

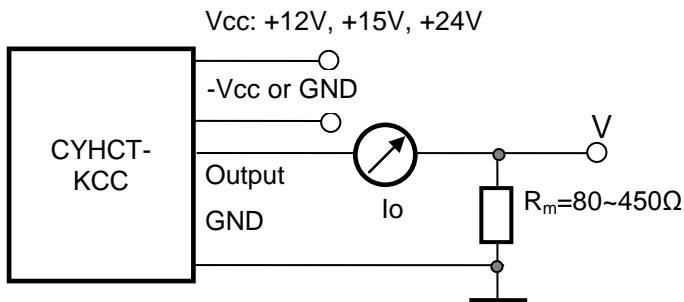
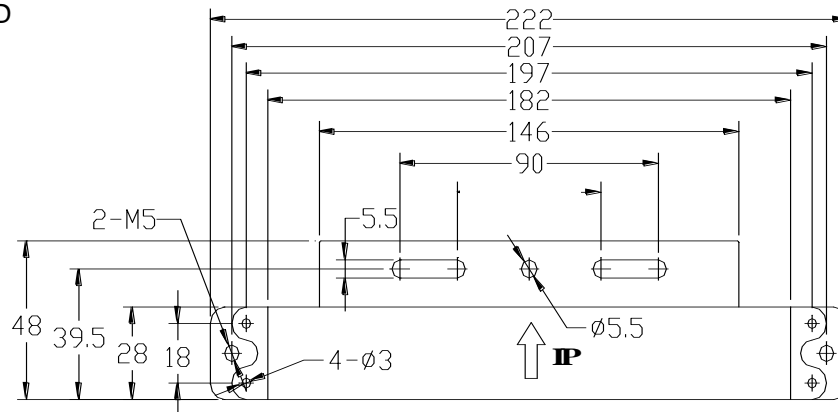
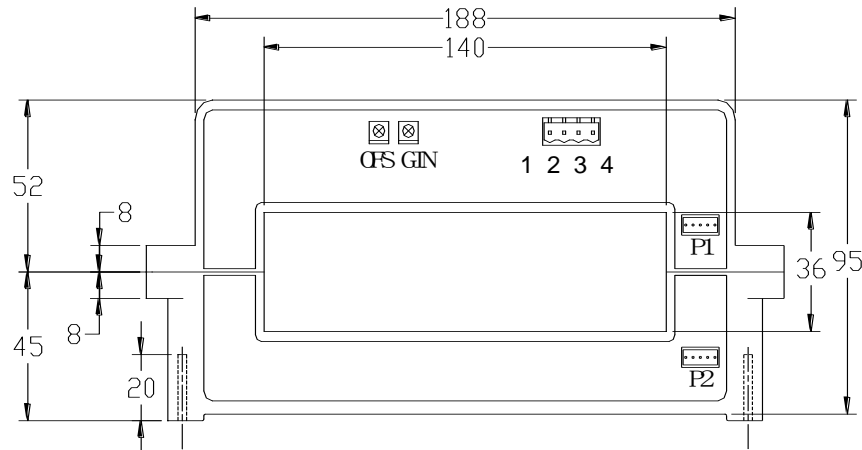

Notes:

1. Connect the terminals of power source, output respectively and correctly, never make wrong connection.
2. Two potentiometers can be adjusted, only if necessary, by turning slowly to the required accuracy with a small screwdriver.
3. The best accuracy can be achieved when the window is fully filled with bus-bar (current carrying conductor).
4. The in-phase output can be obtained when the direction of current of current carrying conductor is the same as the direction of arrow marked on the transducer