

CYSJ119 GaAs HALL-EFFECT ELEMENTS

CYSJ series Hall-effect element is an ion-implanted magnetic field sensor made of mono-crystal gallium arsenide (GaAs) semiconductor material group III-V using ion-implanted technology. It can convert a magnetic flux density signal linearly into voltage output.

FEATURES

- High Linearity
- Superior Temperature Stability
- Miniature Package

TYPICAL APPLICATION

- Magnetic Field Measurement
- DC Brushless Motor
- Current Sensor
- Non-contact Switch
- Position Control
- Detection Of Revolution

BLOCK DIAGRAM

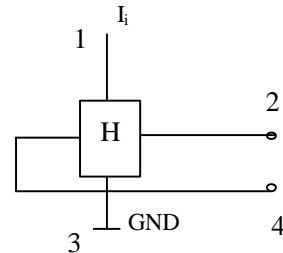

ABSOLUTE MAXIMUM RATING

Parameter	Symbol	Value	Unit
Max. Input current	I_i	10	mA
Operating temperature range	T_A	-55~125	°C
Storage temperature range	T_S	-55~150	°C

ELECTRICAL CHARACTERISTICS ($T_A=25^{\circ}\text{C}$)

Parameter	Symbol	Test conditions	Value	Unit
Hall output voltage	V_H	$B=100\text{mT}$ $I_i=5\text{mA}$	120~150	mV
Offset voltage	V_o/V_H	$I_i=5\text{mA}$ $B=0/B=100\text{mT}$	≤ 12	%
Input resistance	R_i	$I_i=1\text{mA}$	900~1100	Ω
Output resistance	R_o	$I_i=1\text{mA}$	1800~2200	Ω
Temperature coefficient of hall output voltage	αV_H	$I_i=5\text{mA}$ $B=100\text{mT}$	-0.07	%/°C
Temperature coefficient of input and output resistance	α_i, V_o	$I_i=1\text{mA}$ $B=0\text{mT}$	0.3	%/°C
Linearity	ΔK_H	$I_i=5\text{mA}$ $B=0\sim 300\text{mT}$	< 2	%

Package Outline Drawing (Unit: mm)

PIN
1 (+), 3(-): INPUT
2 (+), 4(-): OUTPUT

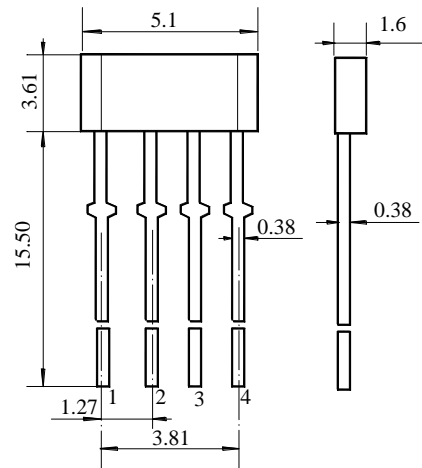

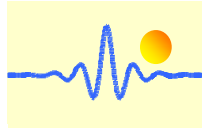

Characteristics Curves

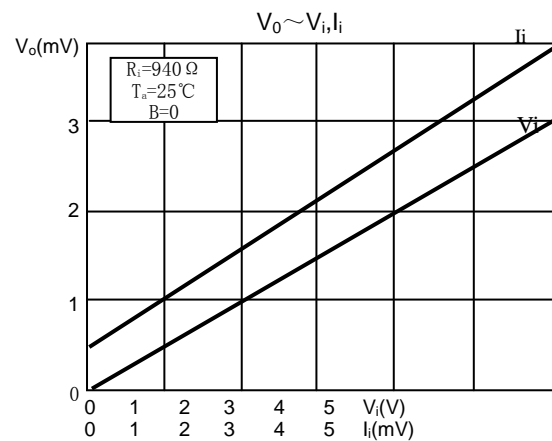
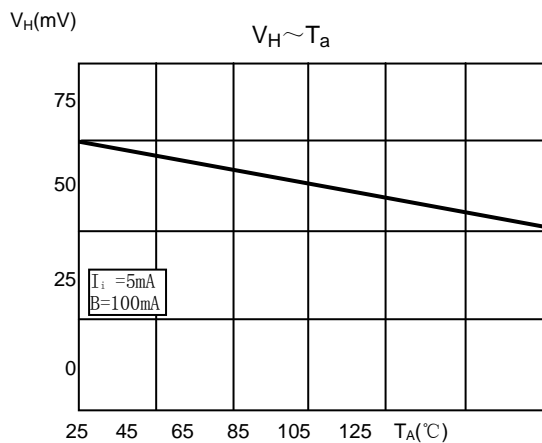
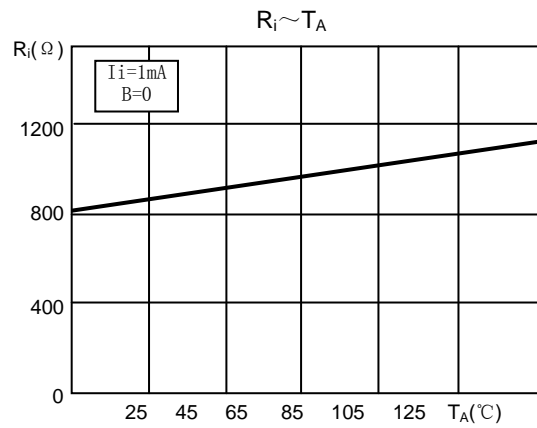
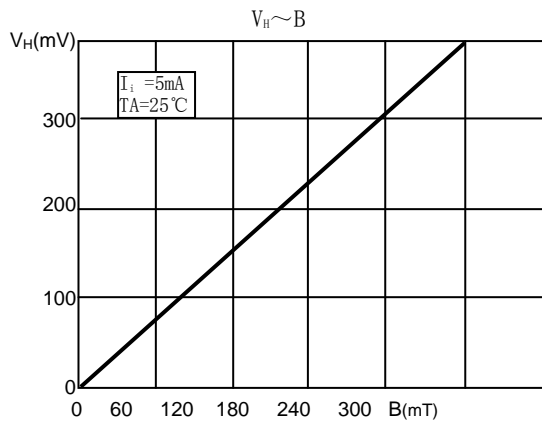
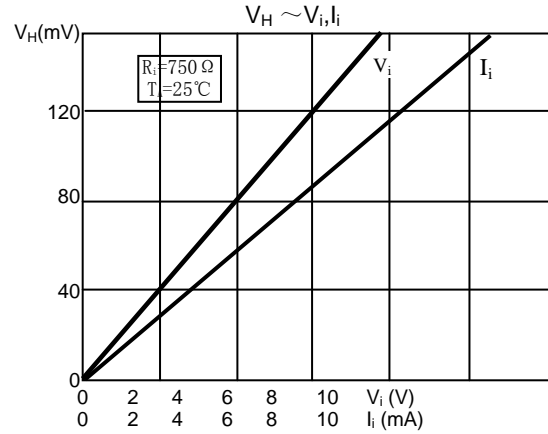
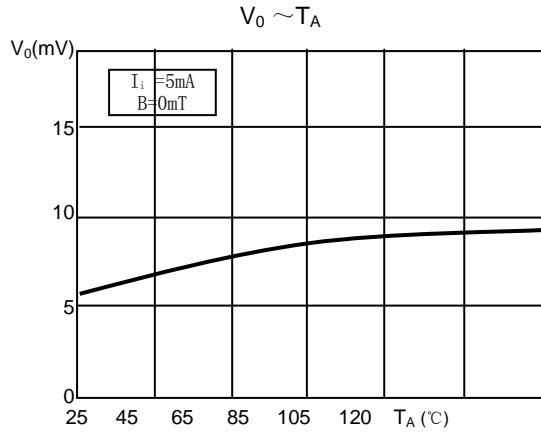

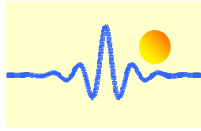

Connection

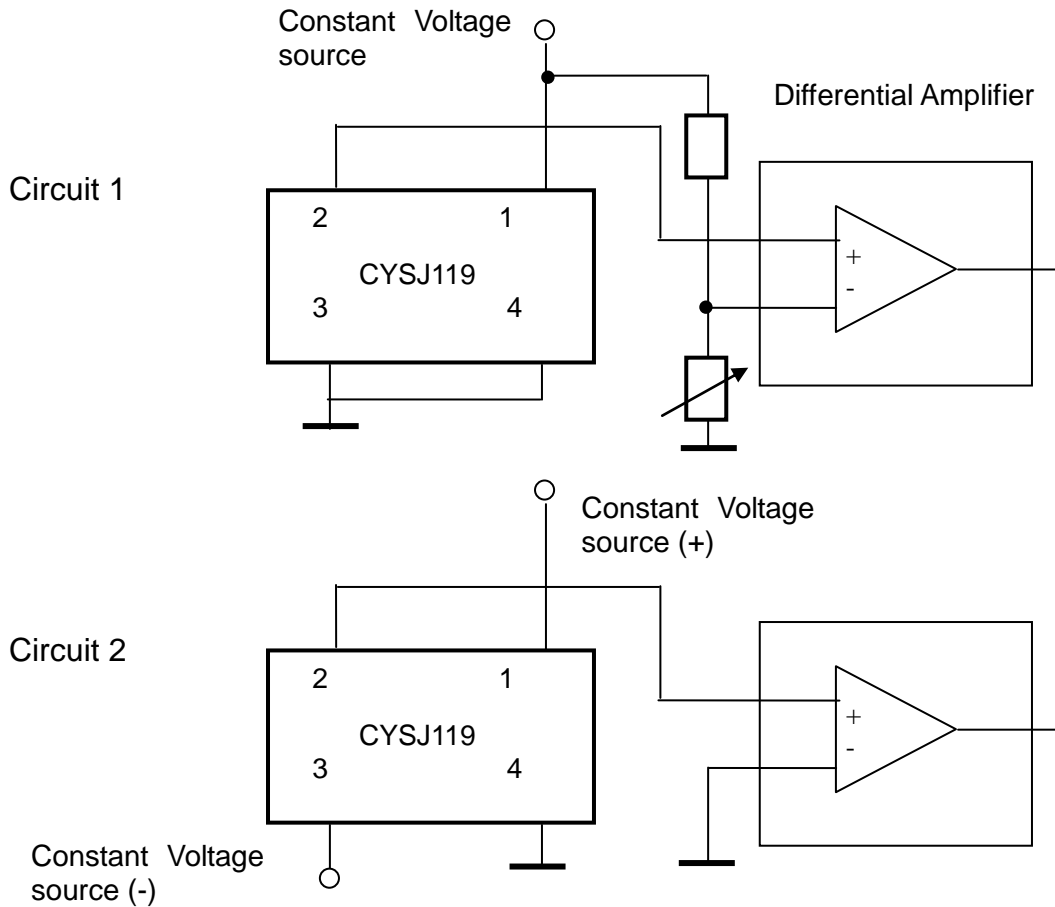

Application Notes

The Hall voltage V_H can be positive and negative. But if one connects the sensor as follows (circuit 1):

Pin 1: positive input voltage V_+ , for instance +5VDC.
Pin 3: GND
Pin 2: OUTPUT
Pin 4: GND

One can only measure the positive voltage at the pin 2. This means that the output voltage at zero magnetic field is not zero. This voltage is called as offset voltage. The output voltage in this case is not equal to the Hall voltage. The output voltage is equal to the sum of offset voltage and Hall voltage.

The offset voltage will be zero if you connect double power supplies V_+ and V_- to the sensor (circuit 2):

Pin 1: positive input voltage V_+ , for instance +5VDC.
Pin 3: negative input voltage V_- , for instance -5VDC
Pin 2: OUTPUT
Pin 4: GND

In this case the output voltage is equal to the Hall Voltage.