

CYSJ302C GaAs HALL-EFFECT ELEMENTS

CYSJ302C series Hall-effect element is a ion-implanted magnetic field sensor made of mono-crystal gallium arsenide (GaAs) semiconductor material group III-V using ion-implanted technology. It can convert a magnetic flux density signal linearly into voltage output.

FEATURES

- High Linearity
- Superior Temperature Stability
- Miniature Package
- Replacements of **THS119**, **KSY14** and **KSY44** etc.

TYPICAL APPLICATION

- Magnetic Field Measurement
- DC Brushless Motor
- Current Sensor
- Non-contact Switch
- Position Control
- Detection of Revolution

BLOCK DIAGRAM

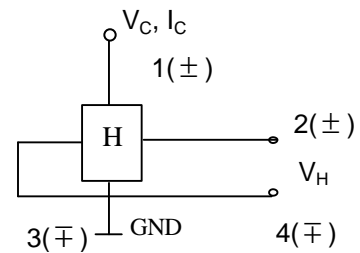

ABSOLUTE MAXIMUM RATINGS

Parameter	Symbol	Value	Unit
Max. Input Voltage	V_C	10V	V
Max. Input Power	P_D	150	mW
Operating temperature range	T_A	-40~125	°C
Storage temperature range	T_S	-40~150	°C
MTBF (Mean Time Between Failure)		>100k	hour

ELECTRICAL CHARACTERISTICS ($T_A=25^\circ\text{C}$)

Parameter	Symbol	Test conditions	Value	Unit
Hall output voltage	V_H	$B=50\text{mT}$, $V_C=6\text{V}$	55~75	mV
Offset voltage	$V_{OS}(V_u)$	$V_C=6\text{V}$, $B=0$	± 11	mV
Input resistance	R_{in}	$B=0\text{mT}$, $I_C=0.1\text{mA}$	650~850	Ω
Output resistance	R_{out}	$B=0\text{mT}$, $I_C=0.1\text{mA}$	650~850	Ω
Temperature coefficient of Hall output voltage	αV_H	$I_C=5\text{mA}$, $B=50\text{mT}$ ($T_a=25^\circ\text{C} \sim 125^\circ\text{C}$)	Max: -0.06	%/°C
Temperature coefficient of input resistance	αR_{in}	$I_C=0.1\text{mA}$, $B=0\text{mT}$ ($T_a=25^\circ\text{C} \sim 125^\circ\text{C}$)	0.3	%/°C
Linearity	ΔK_H	$I_C=5\text{mA}$ $B=0.1/0.5\text{T}$	2	%

Notes: $V_H = V_{HM} - V_{OS}(V_u)$ (V_{HM} : measured voltage)

$$\alpha V_H = \frac{1}{V_H(T_1)} \times \frac{V_H(T_2) - V_H(T_1)}{T_2 - T_1} \times 100,$$

$$\alpha R_{in} = \frac{1}{R_{in}(T_1)} \times \frac{R_{in}(T_2) - R_{in}(T_1)}{T_2 - T_1} \times 100$$

$$\Delta K_H = \frac{K(B_1) - K(B_2)}{[K(B_1) + K(B_2)]} \times 200$$

$$K_H = \frac{V_H}{I_C B}$$

$$T_1=25^\circ\text{C}, T_2=125^\circ\text{C}, \quad B_1=0.5\text{T}, B_2=0.1\text{T}$$

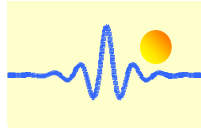

Package Outline Drawing (Unit: mm)

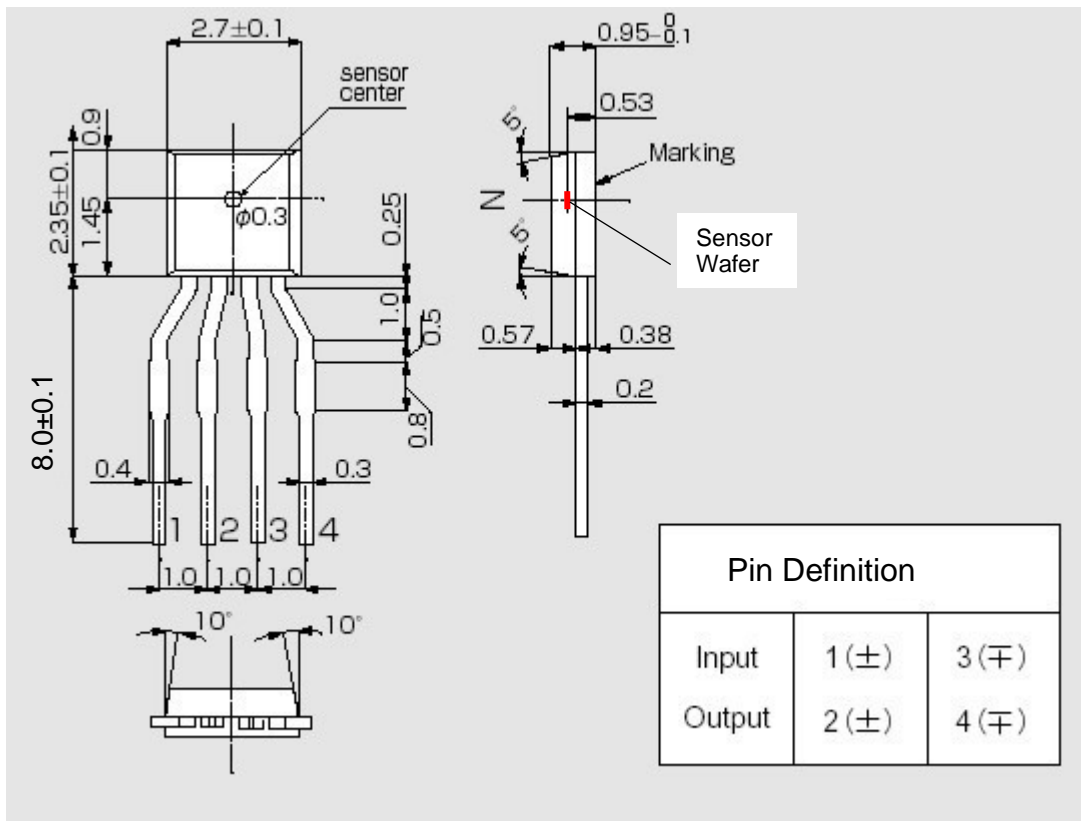
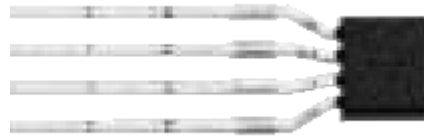

Characteristic Curves

Allowable Package Power Dissipation

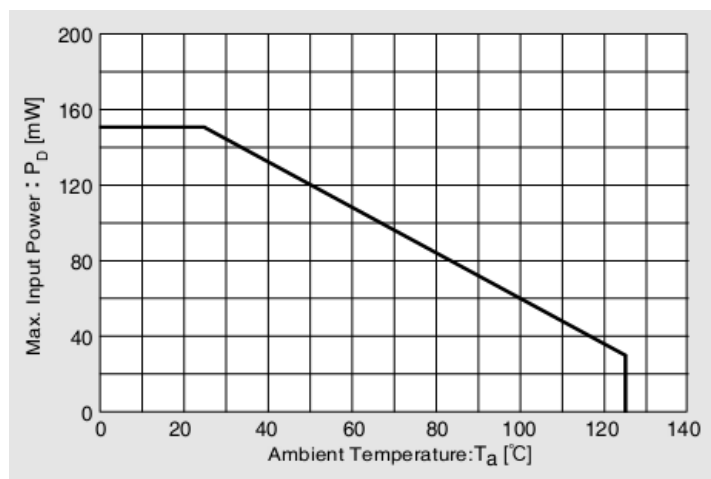

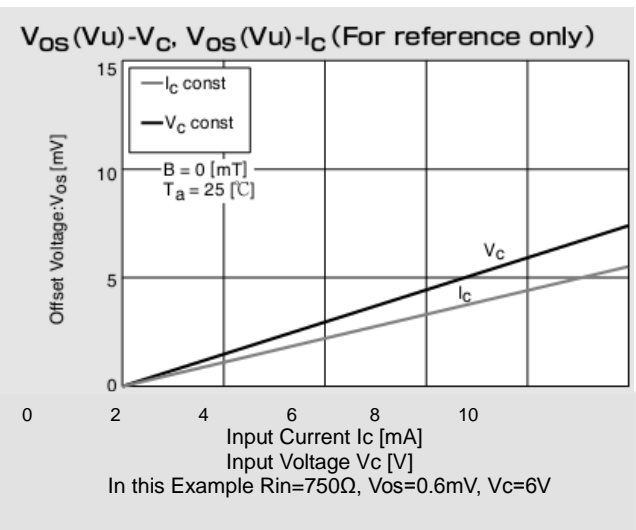
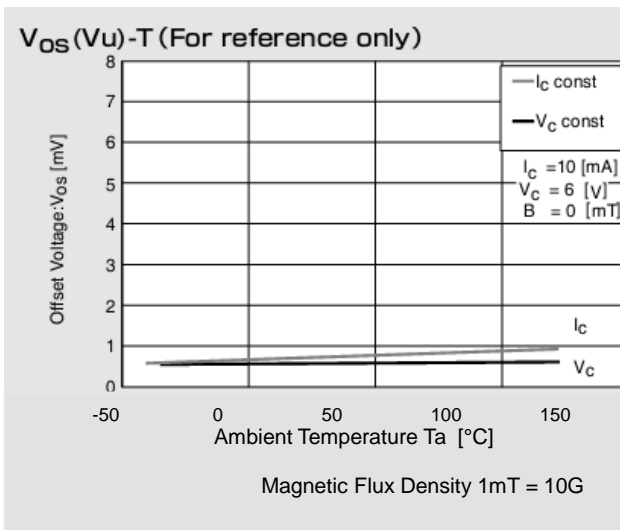
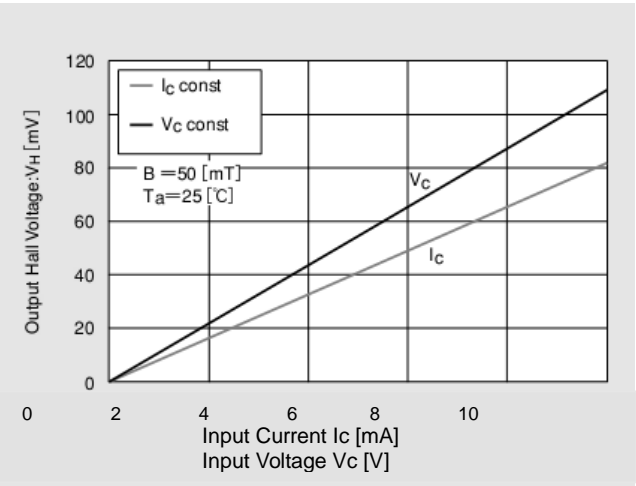
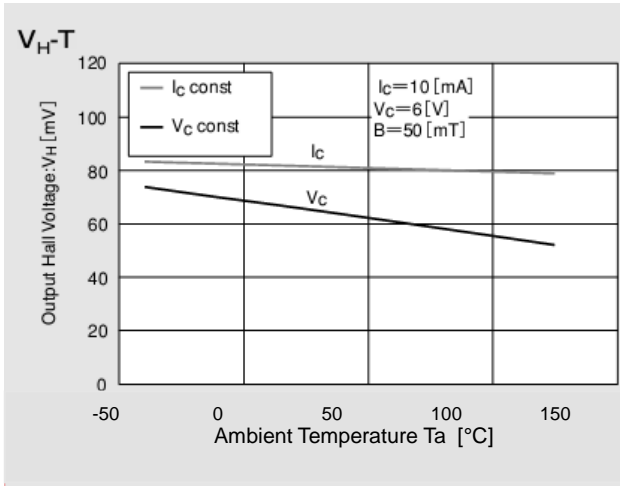
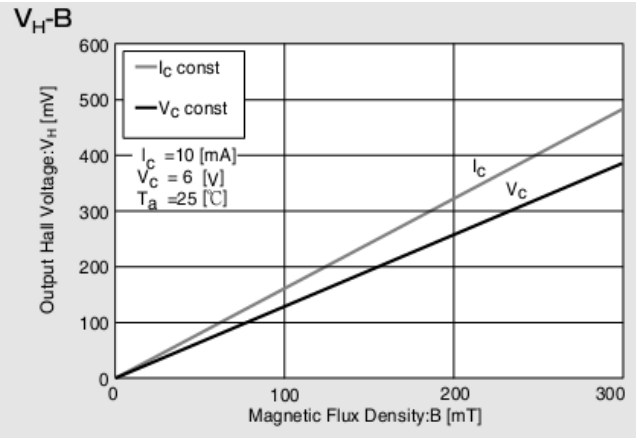
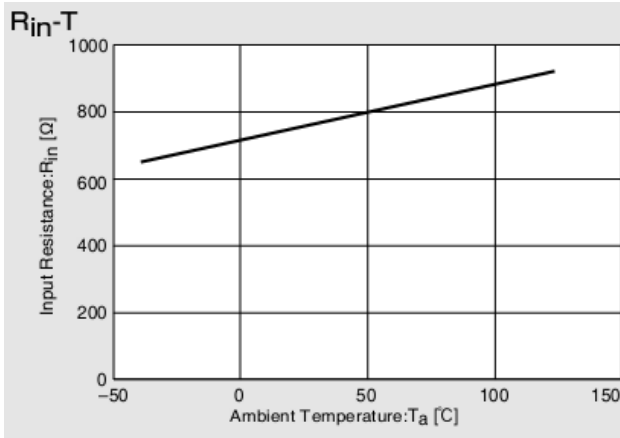
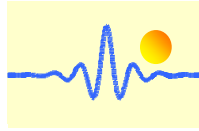

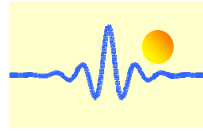

Connection

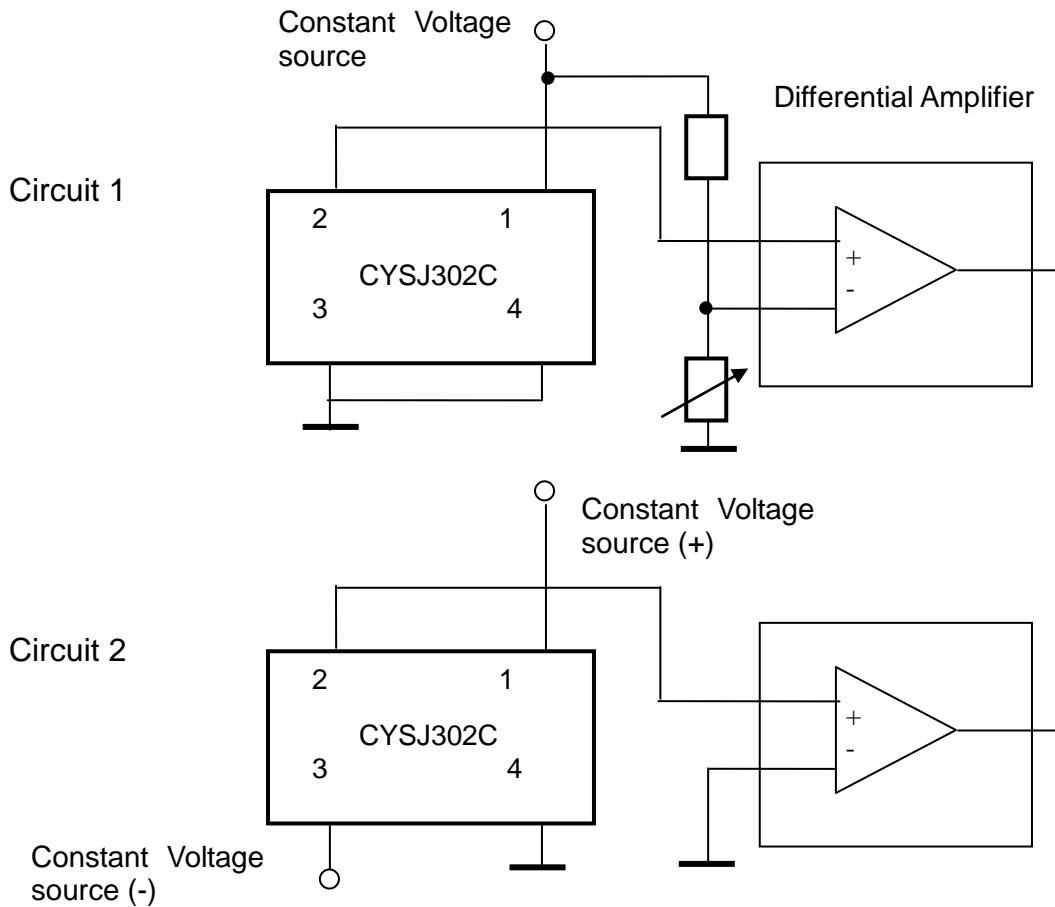

Application Notes

The Hall voltage V_H can be positive and negative. But if one connects the sensor as follows (circuit 1):

- Pin 1: positive input voltage $V+$, for instance +5VDC.
- Pin 3: GND
- Pin 2: OUTPUT
- Pin 4: GND

One can only measure the positive voltage at the pin 2. This means that the output voltage at zero magnetic field is not zero. This voltage is called as offset voltage. The output voltage in this case is not equal to the Hall voltage. The output voltage is equal to the sum of offset voltage and Hall voltage.

The offset voltage will be zero if you connect double power supplies $V+$ and $V-$ to the sensor (circuit 2):

- Pin 1: positive input voltage $V+$, for instance +5VDC.
- Pin 3: negative input voltage $V-$, for instance -5VDC
- Pin 2: OUTPUT
- Pin 4: GND

In this case the output voltage is equal to the Hall Voltage.